



MHRC-AE-060-VS-01

Simultaneous Heating & Cooling (SHC)

Chiller for Solar Applications

5 Ton Nominal Hybrid Heat/Cool Chiller

Primary - DC (380V) / Secondary - AC (208/230-1-50/60)

*These specifications are subject to change without notice.
Check www.multiaqua.com for the latest information.*

Rev. 1.15

HVAC Guide Specifications

Air-Cooled Liquid Chiller
Nominal Size: **5 Tons**

MultiAqua Model Number: **MHRC-AE-060-VS-01**

Part 1-General

1.01 System Description

MultiAqua air-cooled and water to water liquid chillers are designed using variable speed scroll compressors, high volume condenser fans and motors.

1.02 Quality Assurance

- A. ETL safety certified to UL Standard 1995, 4th edition (U.S.A.).
- B. UL performance certified.
- C. Third party certified efficiency ratings are at ANSI/AHRI Standard 550/590 with Addendum 3-2011 conditions.
- D. Manufactured in U.S.A.
- E. Fully tested.
- F. Damage resistant packaging.

1.03 Delivery, Storage and Handling

- A. Packaged and readied for shipment from distribution center.
- B. Controls shall be capable of withstanding 150°F storage temperatures in the control compartment.
- C. Stored and handled per manufacturer's recommendations.

Part 2-Product

2.01 Equipment

A. General:

- 1. Unit shall be a factory assembled and tested.
- 2. Shall be assembled on heavy gauge steel mounting/lifting rails.
- 3. Contained within the unit cabinet shall be all factory wiring, piping, controls, refrigerant charge (R410a), POE oil and special accessories required prior to start up.
- 4. Brass body strainers with 20 mesh screen and blow down shall be supplied in cabinet as a field installable accessory.

B. Unit Cabinet:

- 1. Composed of heavy gauge galvanized steel casing with a baked polyester powder coating.
- 2. Capable of withstanding 500-hour salt spray test in accordance with the ASTM (U.S.A.) standard.

C. Condenser Fans:

- 1. Five blade glass reinforced polypropylene (PP) petals mounted on a cast aluminum hub construction and shall be dynamically balanced and corrosion resistant.
- 2. Discharge air is vertical.
- 3. Motors and blades shall be protected by coated steel wire safety guards.

D. Fan Motors:

- 1. Condenser fan motor shall be variable speed, brushless DC type.
- 2. Condenser fan motors shall be Totally Enclosed Air Over (TEAO), use Class B insulation, and permanently lubricated ball and/or sleeve bearings.
- 3. Condenser fan motors shall be internally overload protected with automatic reset.

E. Compressor:

1. Unit shall contain one Emerson/Copeland variable speed DC scroll compressor.
2. Direct current DC, 900-7,200 rpm (15-120Hz).
3. Compressor motor shall be suction gas cooled.
4. External motor protection.
5. Externally protected by low and high pressure cutout devices and discharge temperature sensing thermistor.
6. Individual vibration isolators.
7. Compressor compartment is internally insulated using noise reducing elastomeric foam insulation.

F. Solar Inverter:

1. Unit shall contain one Pika 7601C Power Core Inverter matched with S2501 PV links at solar panels.

G. Pump:

1. Unit shall not be capable of incorporating a field installed chilled liquid solution pump internally. (Space restricted)
2. Unit shall have chilled liquid solution piping to the exterior of the cabinet.

H. Evaporator (Cooling):

1. Evaporator shall have one refrigerant circuit and one liquid solution circuit.
2. Evaporator rated for a refrigerant side working pressure up to 550 psig.
3. Evaporator rated for a water side working pressure up to 150 psig.
4. Single pass, ANSI type 316 stainless steel, brazed plate construction with copper/nickel brazing material.

I. Condenser (Heating):

1. Condenser shall have one refrigerant circuit and one liquid solution circuit.
2. Condenser rated for a refrigerant side working pressure up to 550 psig.
3. Condenser rated for a water side working pressure up to 150 psig.
4. Single pass, ANSI type 316 stainless steel, brazed plate construction with copper/nickel brazing material.

J. Evaporator/Condenser (Cooling/Heating):

1. Condenser coil shall be air-cooled with integral sub-cooler.
2. Constructed of rifled copper tubing mechanically bonded to aluminum fins.
3. Cleaned and dehydrated.
4. Factory leak tested to 650 psig.

K. Refrigerant Circuits:

1. Each circuit shall contain liquid line strainers, electronic expansion valves, solenoid valve, check valve, refrigerant charge of R410a, and POE compressor oil.

Part 3-Controls and Safeties**3.01 Controls**

- A. Chiller shall be completely factory wired and tested.
- B. Temperature control shall be based on leaving liquid solution temperatures.
 1. Temperature accuracy shall be + - 1°F
- C. Controls shall be capable of variable speed control.
- D. Controls shall include the following components:
 1. 24vac transformers to serve all controllers, relays, and control components.
 2. Microprocessor based liquid solution temperature controller.

3. Leaving water temperature thermistors.
 4. Chilled liquid solution flow switches.
- E. All functions shall be addressable, logic, code, and algorithm controlled.
- F. Ethernet port supplied for communication and monitoring.
- G. Compatible with Building Automation Systems (BAS) using BACnet protocol.

3.02 Safeties

- A. Unit shall be equipped with all necessary components in conjunction with the control system to provide the following protection:
1. Low refrigerant pressure.
 2. High refrigerant pressure.
 3. Water side cold & hot flow.

Part 4-Operating Characteristics

4.01 Temperatures

- A. Unit shall be capable of starting and running at outdoor temperatures from 0°F to 120°F.
- B. Unit shall be capable of initial startup in cooling mode with a maximum 80°F entering fluid temperature and ambient not above 95° F.
- C. Maximum sustained entering fluid solution temperature to the evaporator shall not exceed 70°F in cooling mode.
- D. **Minimum 10% glycol solution is required in all applications. For outdoor temperatures below 32°F, reference the propylene glycol manufacture's data table of field installed polypropylene glycol solution concentrations.**

4.02 Electrical Requirements

- A. Primary DC electrical power supply shall enter the unit at a single location.
- B. Secondary AC electrical power supply if used, shall enter the unit at a single location.
- C. Electrical power supply shall be rated to withstand 90°C operating ambient temperature.

Part 5- Definitions

5.01 Abbreviations

- A. DB = Dry Bulb Temperature
- B. EWT = Entering Water Temperature
- C. LWT = Leaving Water Temperature
- D. EAT = Entering Air Temperature
- E. EAT/DB = Entering Air Temperature Dry Bulb
- F. EAT/WB = Entering Air Wet Bulb
- G. GPM = US Gallons per Minute
- H. MBH = BTU X 1000
- I. SC = Sensible Cooling
- J. TC = Total Cooling = Sensible + Latent
- K. dB = Decibel Level

5.02 Measurements

- A. All measurements with regard to length, width, and height shall be in inches.
- B. All measurements with regard to pipe sizes shall be in outside diameter (OD) unless otherwise noted.

MHRC-AE-060-VS-01 Product Specifications

Physical Data						
Model Number	Chiller				Weight (lbs.)	
	Height (in)	Length (in)	Width (in)	Refrigerant R410a (1 Circuits)	Net	Shipping
MHRC-AE-060-VS-01	63-1/2	33-5/8	52-1/2	13.5 lbs. / 216 oz.	700	900

Simultaneous Heat & Cool (SHC) Mode Electrical Data								
Model Number	Volts/ Phase/ Hertz	Compressor (Qty 1)		Condenser Fan Motor (Qty 1)		SCCR	Fuse or HACR Circuit Breaker	
		(RLA)	(LRA)	(RLA)	(RPM)		Minimum Amps (MCA)	Maximum Amps (MOCP)
MHRC-AE-060-VS-01	DC (380V) Primary AC (208/230-1-50/60) Secondary	8 to 25	~	~*	~*	10kA	40	50

* Condenser fan does not run when MHRC2 is in Simultaneous Heat & Cool (SHC) Mode.

Cooling Mode Electrical Data								
Model Number	Volts/ Phase/ Hertz	Compressor (Qty 1)		Condenser Fan Motor (Qty 1)		SCCR	Fuse or HACR Circuit Breaker	
		(RLA)	(LRA)	(RLA)	(RPM)		Minimum Amps (MCA)	Maximum Amps (MOCP)
MHRC-AE-060-VS-01	DC (380V) Primary AC (208/230-1-50/60) Secondary	8 to 21	~	2.5	1200/VAR*	10kA	40	50

* VAR = Variable Speed

Heating Mode Electrical Data								
Model Number	Volts/ Phase/ Hertz	Compressor (Qty 1)		Condenser Fan Motor (Qty 1)		SCCR	Fuse or HACR Circuit Breaker	
		(RLA)	(LRA)	(RLA)	(RPM)		Minimum Amps (MCA)	Maximum Amps (MOCP)
MHRC-AE-060-VS-01	DC (380V) Primary AC (208/230-1-50/60) Secondary	8 to 31	~	2.5	1200/VAR*	10kA	40	50

* VAR = Variable Speed

MHRC-AE-060-VS-01 Product Specifications

Compressor	Copeland Variable Speed (VS) Scroll
Refrigerant	R410a
Heat Exchanger (Cooling)	Brazed Plate
Heat Exchanger (Heating)	Brazed Plate
Max. Flow Rate (Cooling)	14.4 gpm
Min. Flow Rate (Cooling)	12 gpm
Max. Flow Rate (Heating)	14.4 gpm
Min. Flow Rate (Heating)	12 gpm
Supply Water Temp (Cooling)	44°F (Adjustable)
Return Water Temp (Cooling)	54°F (Adjustable)
Minimum Supply Water Temp (Cooling)	28°F*
Minimum Return Water Temp (Cooling)	38°F*
Maximum Supply Water Temp (Heating)	130°F*
Maximum Return Water Temp (Heating)	120°F*
Minimum System Solution Content (Cold Side)	25 Gallons
Minimum System Solution Content (Hot Side)	25 Gallons
Expansion Tank Size	3% of Total System
Water Connections (4)	1.00" MPT Supply & Return

* Compatible with Thermal Storage (TS) systems.

MHRC-AE-060-VS-01 Performance Data

Simultaneous Heat/Cool (SHC) Mode

LWT (°F)	Simultaneous Cooling	Simultaneous Heat/Cool			Simultaneous Heating	LWT (°F)
	BTU's	Total BTU's	COP	EER	BTU's	
44	46839	105534	7.76	26.49	58695	105

- Condenser fan does not run when MHRC2 is in Simultaneous Heat & Cool (SHC) mode.
- Compressor running at 5000 RPM in SHC mode.

LWT (°F)	Simultaneous Cooling	Simultaneous Heat/Cool			Simultaneous Heating	LWT (°F)
	BTU's	Total BTU's	COP	EER	BTU's	
44	43080	100383	5.95	20.29	57303	120

- Condenser fan does not run when MHRC2 is in Simultaneous Heat & Cool (SHC) mode.
- Compressor running at 5000 RPM in SHC mode.

LWT (°F)	Simultaneous Cooling	Simultaneous Heat/Cool			Simultaneous Heating	LWT (°F)
	BTU's	Total BTU's	COP	EER	BTU's	
44	41827	98666	5.49	18.73	56839	125

- Condenser fan does not run when MHRC2 is in Simultaneous Heat & Cool (SHC) mode.
- Compressor running at 5000 RPM in SHC mode.

LWT (°F)	Simultaneous Cooling	Simultaneous Heat/Cool			Simultaneous Heating	LWT (°F)
	BTU's	Total BTU's	COP	EER	BTU's	
44	40575	96949	5.08	17.34	56375	130

- Condenser fan does not run when MHRC2 is in Simultaneous Heat & Cool (SHC) mode.
- Compressor running at 5000 RPM in SHC mode.

MHRC-AE-060-VS-01 Performance Data

Cooling Mode

LWT (°F)	Entering Air Temperature			Entering Air Temperature			Entering Air Temperature			Entering Air Temperature		
	55°F			65°F			80°F			95°F		
	<u>BTU's</u>	<u>COP</u>	<u>EER</u>	<u>BTU's</u>	<u>COP</u>	<u>EER</u>	<u>BTU's</u>	<u>COP</u>	<u>EER</u>	<u>BTU's</u>	<u>COP</u>	<u>EER</u>
44	53084	5.94	20.26	54996	4.98	17.00	47314	3.77	12.86	46500	3.00	10.22
IPLV 15.58												

■ Compressor running at 5000 RPM in cooling mode.

Heating Mode

<u>LWT (°F)</u>	Entering Air Temperature		
	47°F		
	<u>BTU's</u>	<u>COP</u>	<u>EER</u>
105°	66365	2.91	9.93

Entering Air Temperature			<u>LWT (°F)</u>
47°F			
<u>BTU's</u>	<u>COP</u>	<u>EER</u>	
64641	2.63	8.96	120°

<u>LWT (°F)</u>	Entering Air Temperature		
	47°F		
	<u>BTU's</u>	<u>COP</u>	<u>EER</u>
125°	64066	2.54	8.66

Entering Air Temperature			<u>LWT (°F)</u>
47°F			
<u>BTU's</u>	<u>COP</u>	<u>EER</u>	
63492	2.46	8.39	130°

■ Compressor running at 6000 RPM in heating mode.

<u>LWT (°F)</u>	Entering Air Temperature		
	17°F		
	<u>BTU's</u>	<u>COP</u>	<u>EER</u>
105°	45853	2.11	7.20

Entering Air Temperature			<u>LWT (°F)</u>
17°F			
<u>BTU's</u>	<u>COP</u>	<u>EER</u>	
43653	1.96	6.70	120°

<u>LWT (°F)</u>	Entering Air Temperature		
	17°F		
	<u>BTU's</u>	<u>COP</u>	<u>EER</u>
125°	42919	1.92	6.54

Entering Air Temperature			<u>LWT (°F)</u>
17°F			
<u>BTU's</u>	<u>COP</u>	<u>EER</u>	
42186	1.87	6.39	130°

■ Compressor running at 6000 RPM in heating mode.

MHRC-AE-060-VS-01 Glycol Adjustment Factors

Glycol Solution Concentration Data	
Propylene Glycol %	Min. Ambient Temp
10%	26°F
20%	18°F
30%	8°F
40%	-7°F
50%	-29°F

<u>Estimated Propylene Glycol Adjustment Factors:</u>		
Percent of Propylene Glycol	Capacity adjustment	Pressure Drop adjustment
	Multiply TONS by:	Multiply PD by:
10%	0.995	1.02
15%	0.992	1.04
20%	0.986	1.08
25%	0.972	1.13
30%	0.96	1.21
35%	0.95	1.26
40%	0.928	1.47
50%	0.878	2.79

Important

Required Use of 10% Minimum Propylene Glycol

MultiAqua Inc. requires a minimum concentration of 10% propylene glycol in the chiller system solution. This requirement applies to all chiller product models for protection of the brazed plate heat exchanger (BPHE), regardless of outdoor ambient operating temperature.

The MultiAqua chiller operating at a 44 leaving water temperature (LWT) will have an internal BPHE temperature of 32 F to 38 F. Without the required MINIMUM 10% concentration of propylene glycol, the unit is susceptible to areas of freezing within the BPHE which could result in failure of the BPHE.

With any deviation from full flow through the BPHE, the BPHE would also be susceptible to areas of freezing within the BPHE. This could be caused by, but not limited to, contaminants being caught in the wye strainer, flow switch or pump failure. Each chiller is supplied from the factory with a Wye strainer that is to be installed on the inlet (suction) side of the pump on the MAC- 036HE, 048HE, 060HE, 120HE, and MHRC2-060-VS chillers.

Failure to follow this requirement will void the chiller warranty. Failure to comply may result in BPHE failure due to freezing followed by compressor failure, all of which are not covered under MultiAqua’s warranty policy.

MHRC-AE-060-VS-01 Altitude Adjustment Factors

Altitude	Tons
1000 ft.	.995
2000 ft.	.990
3000 ft.	.986
4000 ft.	.983
5000 ft.	.980
6000 ft.	.978

Important notes about Low Ambient Operation:

If the outside temperature is expected to fall below freezing (32°F) in the area where the Multiaqua chiller is to be installed; the installer must take the following precautions. **Failure to do so will void the warranty.**

To not engage in cold ambient mitigation will result in the failure of components such as the heat exchanger, piping, circulating pump, etc.. and or property damage.

- Keep the liquid solution at a minimum of 10% percent Propylene Glycol even in areas where there is no danger of freezing.
- The percentage amount of glycol recommended is dependent on the expected ambient temperatures and the solution makeup recommendation of the glycol manufacturer. For outdoor temperatures below 32°F, reference glycol manufacture's data table of field installed polypropylene glycol solution.
- Ensure the system circulating pump is in a constant energized mode to keep a continuous circulation of liquid solution.

The Multiaqua chiller is a self-contained, air-cooled condenser, coupled with brazed plate heat exchangers (evaporator). The system utilizes a scroll compressor to circulate refrigerant between the condenser and heat exchanger. The refrigerant is metered into the heat exchanger with a electronic expansion valve. Protecting the system are both high and low pressure switches as well as a pump flow switch.

Liquid solution (water and propylene glycol; minimum 10 % is required at any ambient) is circulated through the heat exchangers by externally mounted pumps. The liquid solution flows through the heat exchangers to the system supply piping and on to the air handlers.

MHRC-AE-060-VS-01 Sound Data

MODEL #	MHRC-AE-060-VS-01 (Cooling Mode)
Fan Speed	dB(A) @ 3 m
H	62

MODEL #	MHRC-AE-060-VS-01 (Heating Mode)
Fan Speed	dB(A) @ 3 m
H	62

MODEL #	MHRC-AE-060-VS-01 Simultaneous Heating & Cooling (SHC Mode)
Fan Speed	dB(A) @ 3 m
FAN OFF*	60

* Condenser fan does not run in Simultaneous Heat & Cool (SHC) mode.

MHRC-AE-060-VS-01 Upper Electrical Panel Layout

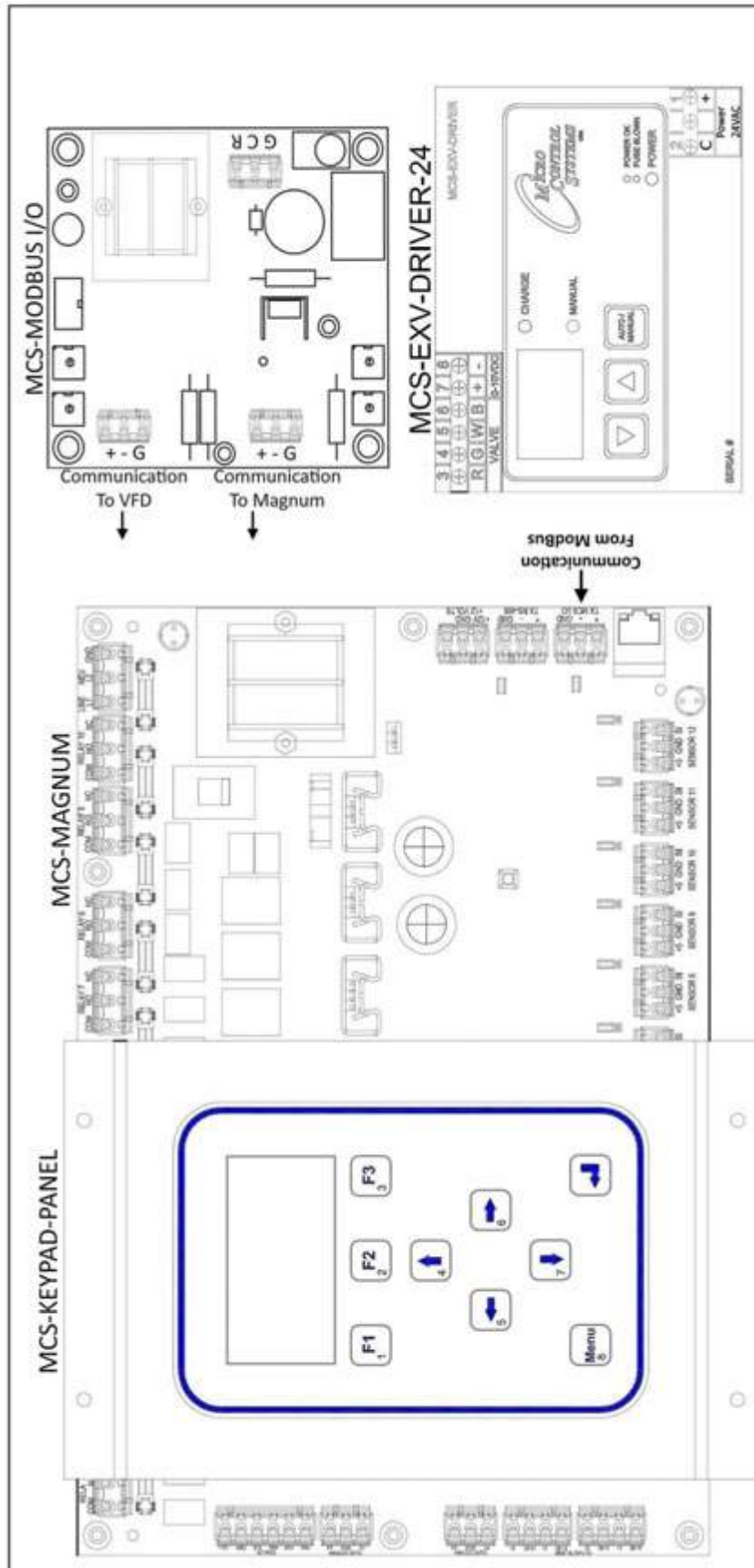

These specifications are subject to change without notice.
 Check www.multiaqua.com for the latest information.

Rev. 1.15

MHRC-AE-060-VS-01 Lower Electrical Panel Layout

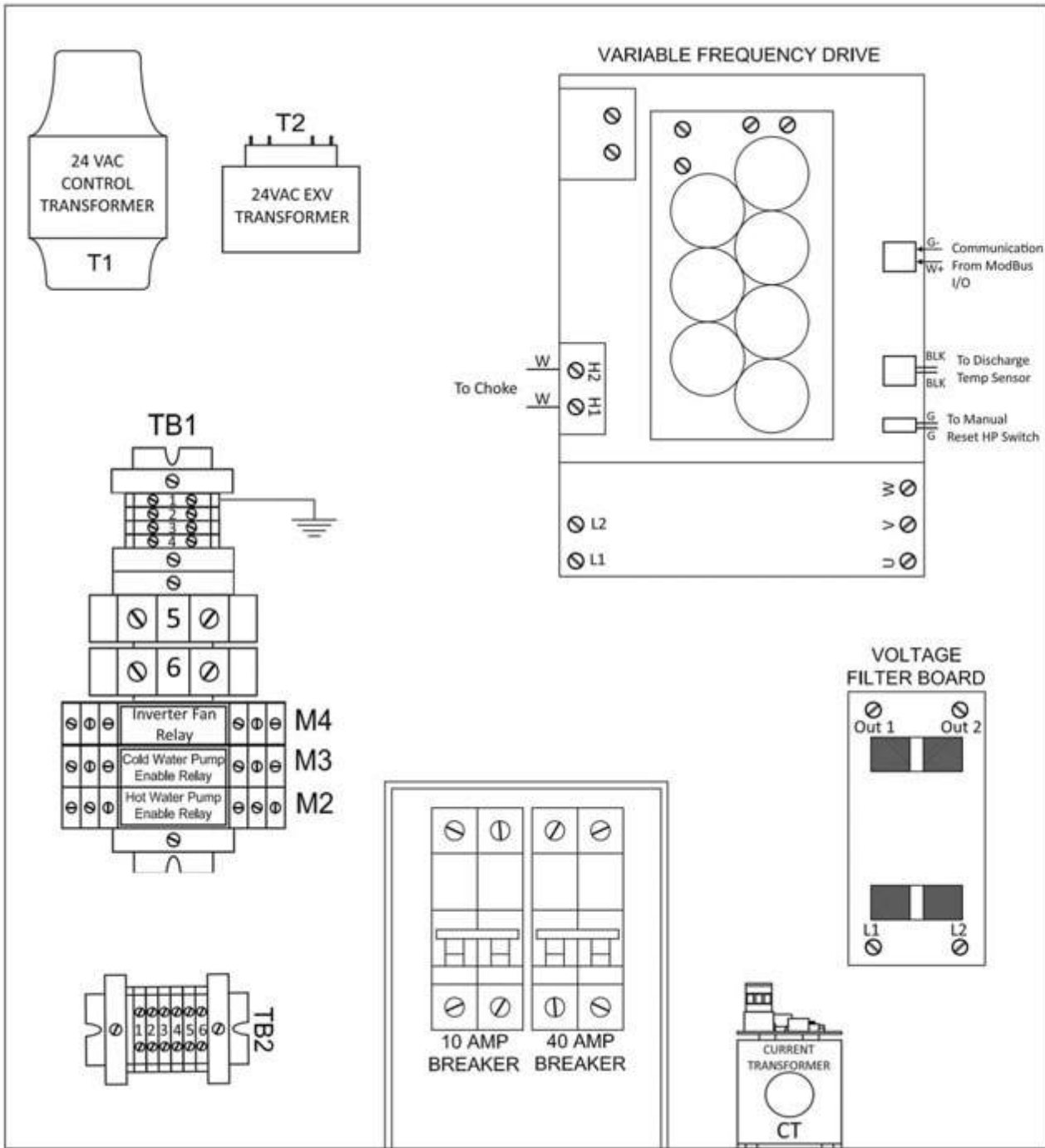

Unit Type	SMHRC2-036, 048, 060-VS-01
CAD Tech	M. LeRoy / C. Ferla
Date	October 6, 2016
Revision	1.1

MHRC-AE-060-VS-01 Low Voltage Wiring Diagram

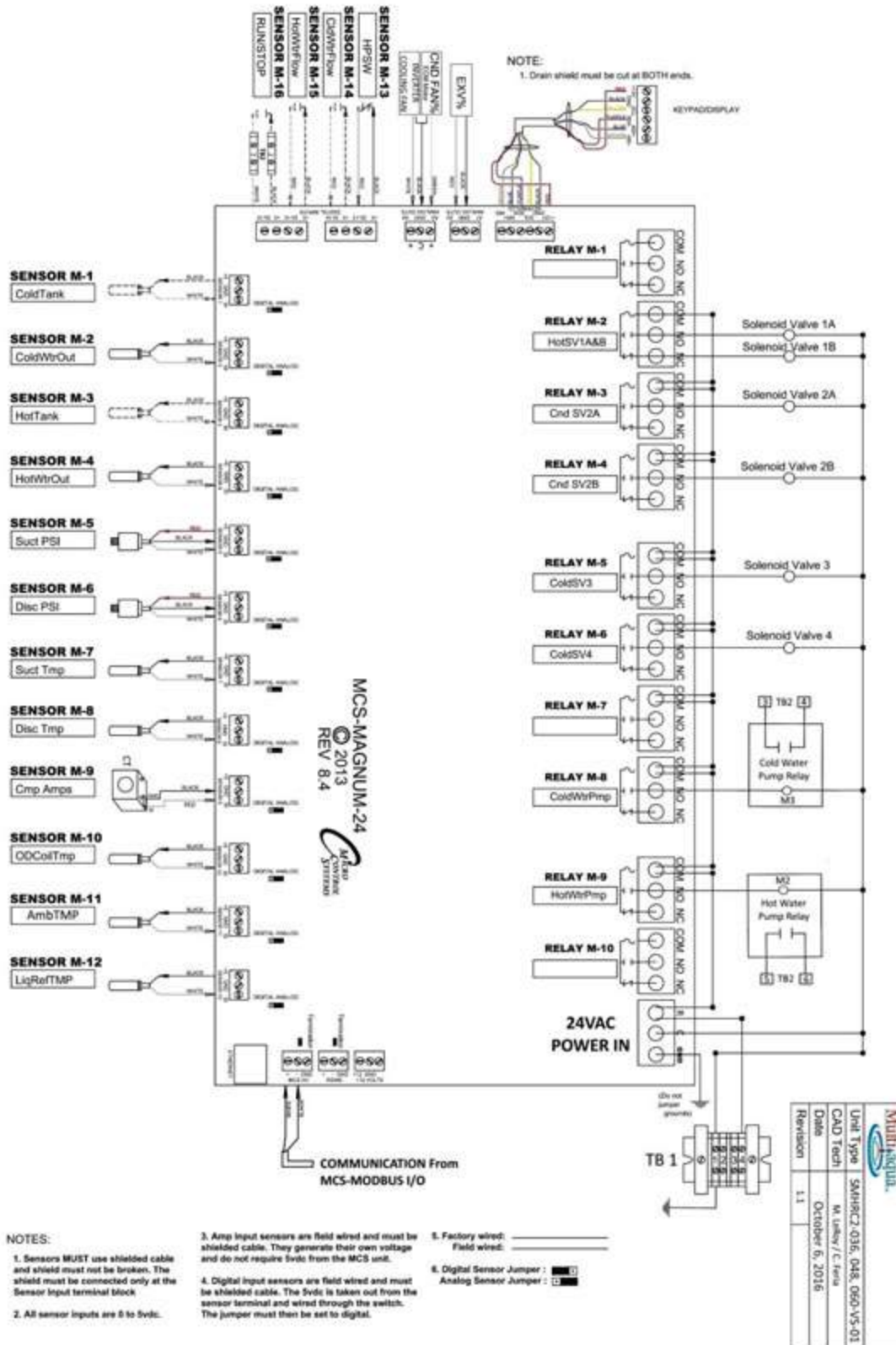

MHRC-AE-060-VS-01 Low Voltage Wiring Diagram (Expanded Upper Section of Diagram)

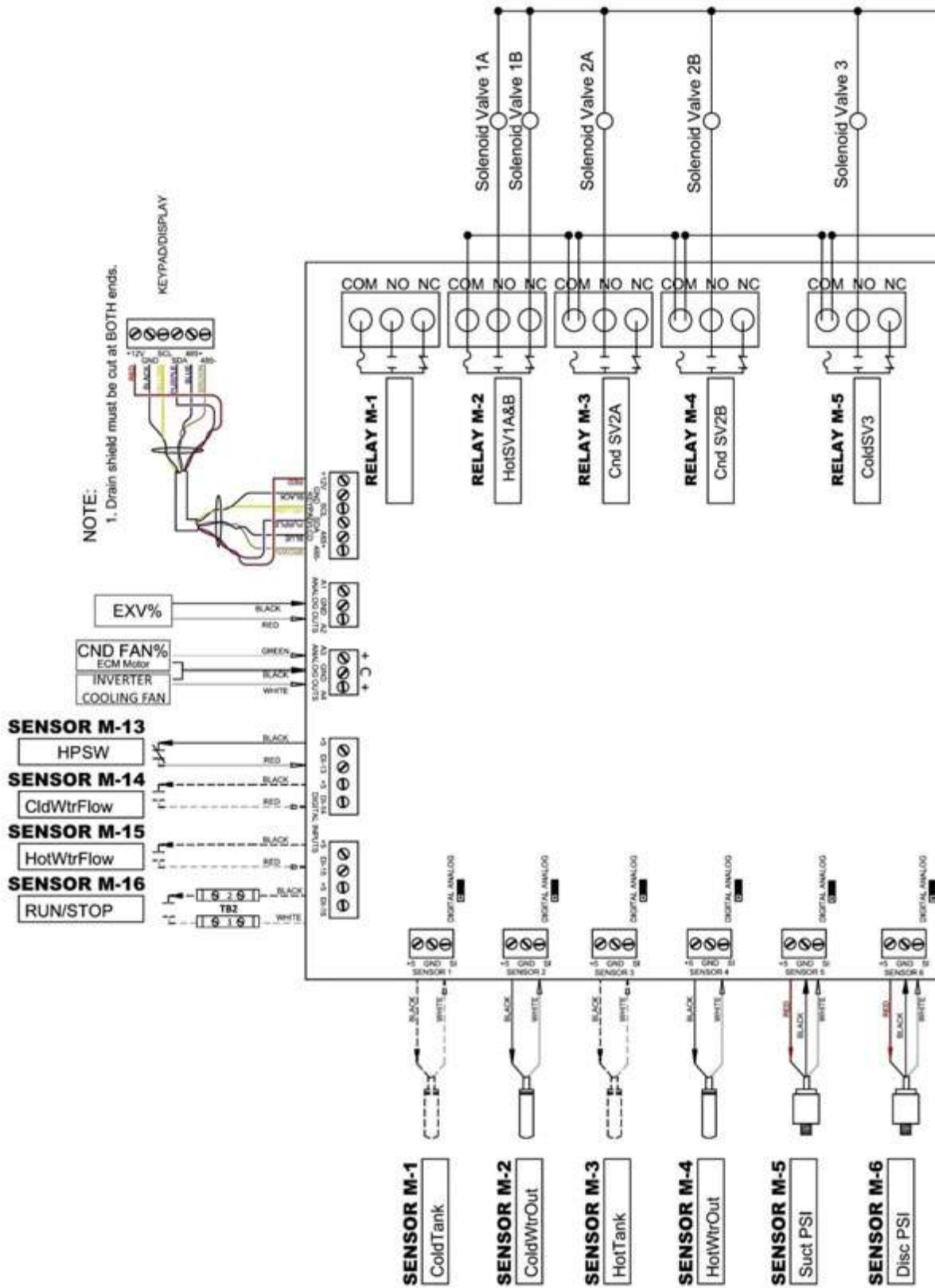

MHRC-AE-060-VS-01 Low Voltage Wiring Diagram (Expanded Lower Section of Diagram)

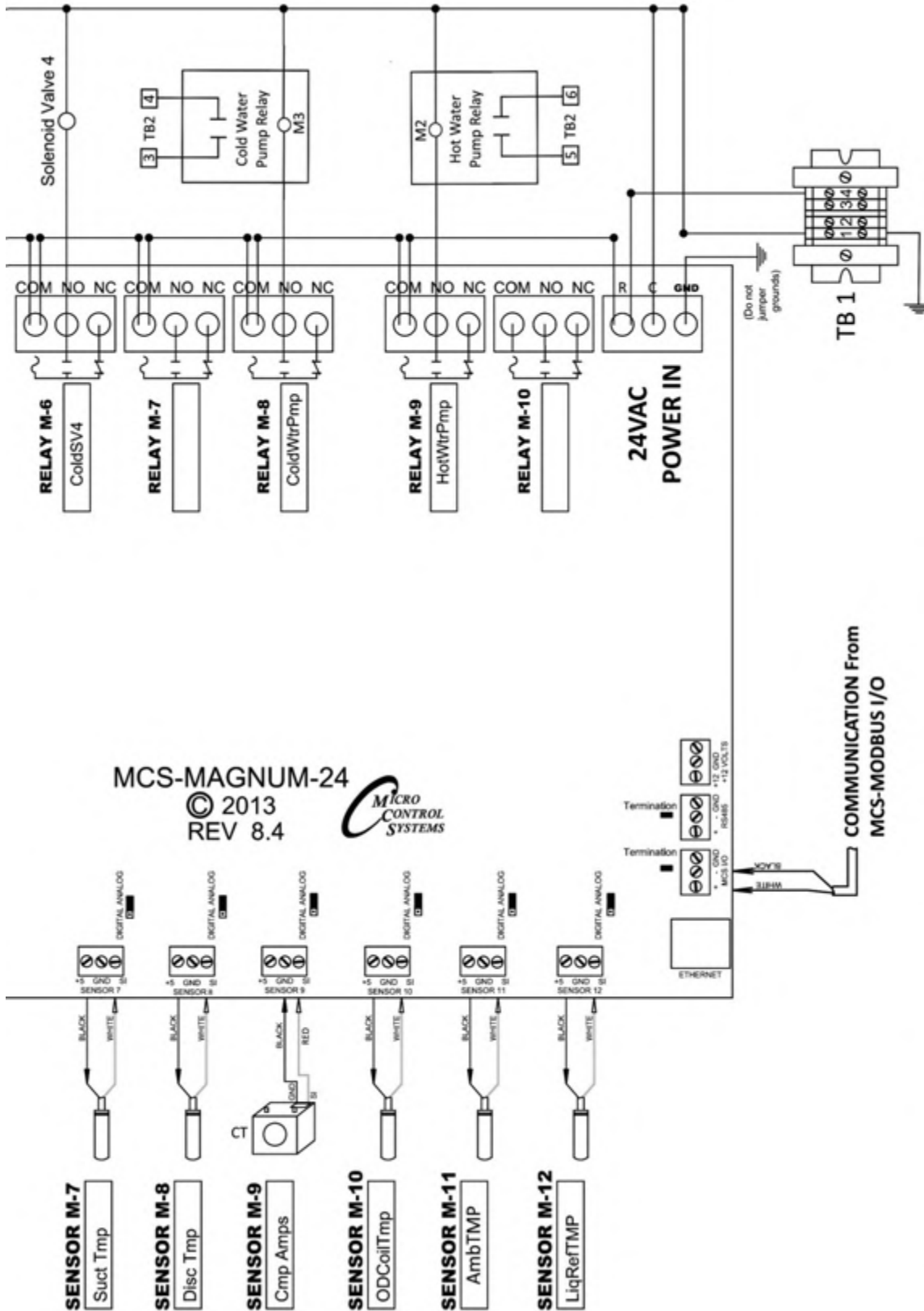

MHRC-AE-060-VS-01 High Voltage Wiring Diagram

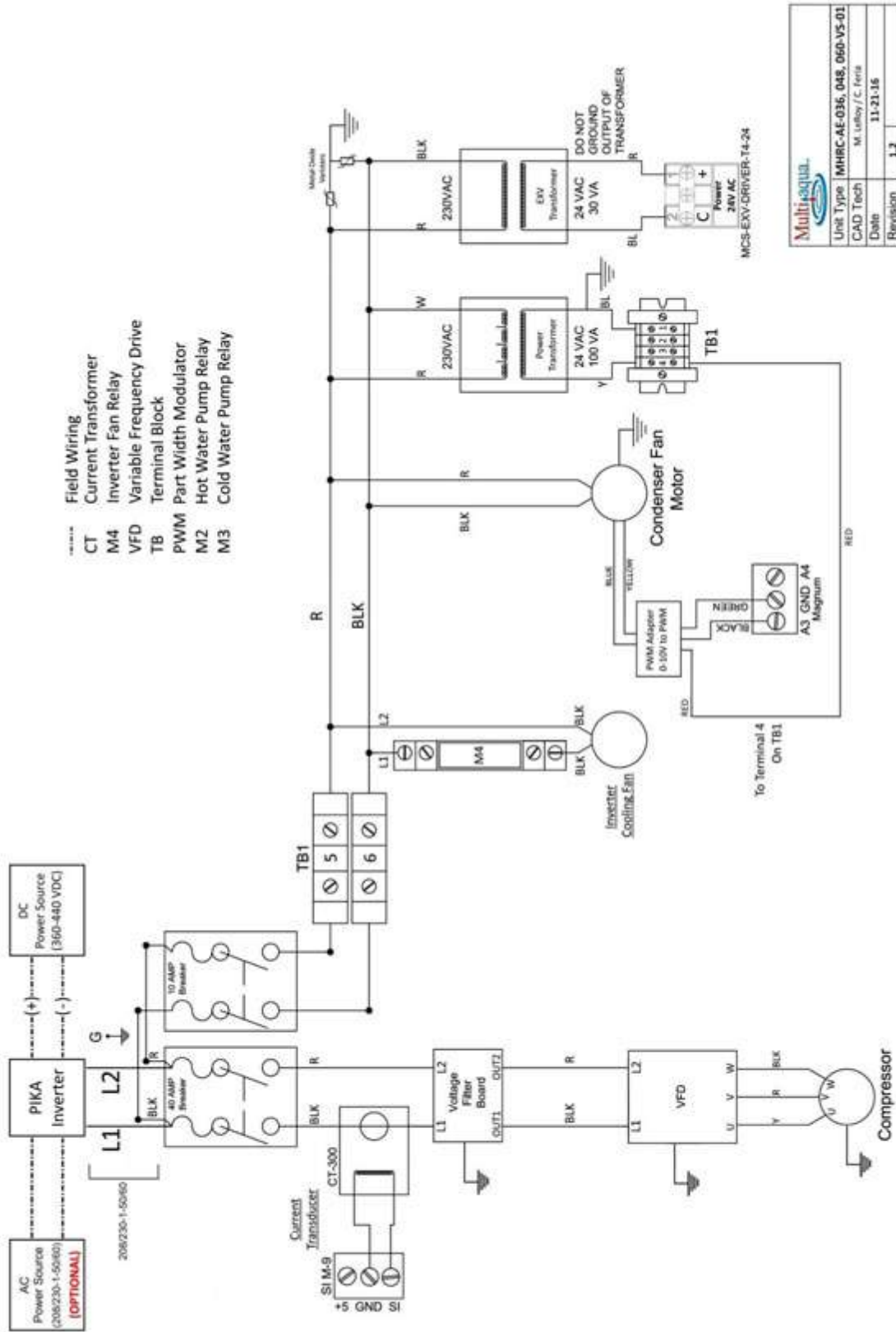

MHRC-AE-060-VS-01 Dimensional Drawing



Model	A	B	C	D	E	F	G	H	I	J
MHRC-AE-060	63.50	52.50	29.00	33.625	27.75	16.75	7.00	18.50	9.50	9.25

Dimensions are in inches.

All supply and return water connections are 1.00" (MPT).



306 Hagood Street
Easley, SC 29640
Ph.: 864-850-8990
Fax: 864-850-8995
www.multiaqua.com

For Technical Assistance:
1-855-THNK-WTR (1-855-846-5987)

*These specifications are subject to change without notice.
Check www.multiaqua.com for the latest information.*

Rev. 1.15