

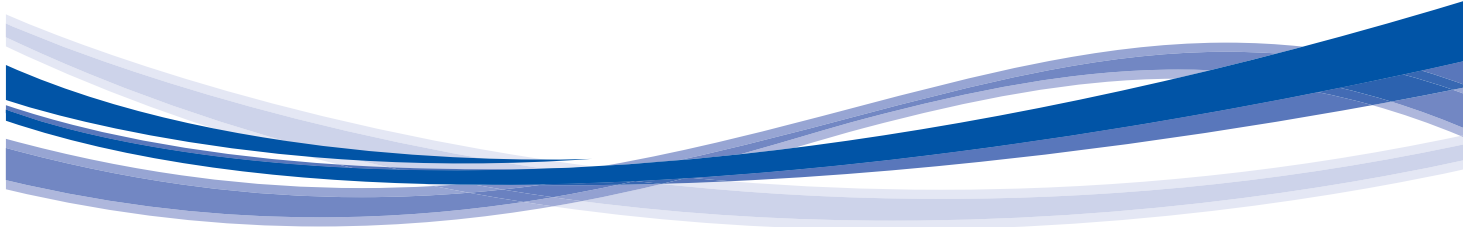

## Product Data

# Gemini™ Select Commercial Air-Cooled Condensing Units

25 to 130 Nominal Tons  
(88 to 457 Nominal kW)



**025 UNIT WITH  
LOW SOUND OPTION**

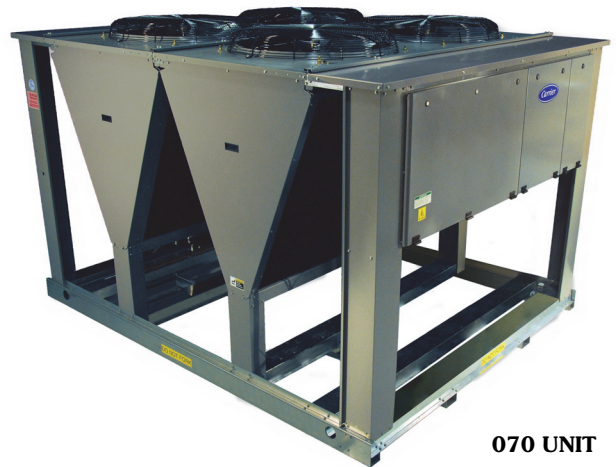

**070 UNIT**



**040-060 UNIT**

38APS025-065, 38APD025-130  
Commercial Air-Cooled Condensing Units  
and 38APS025-050, 38APD025-060  
Commercial Air-Cooled Condensing Units with Greenspeed® Intelligence  
with Puron® Refrigerant (R-410A)  
50/60 Hz

The 38AP condensing unit offers the utmost in system configuration and control adaptability. Its premium-quality standard components ensure durable, efficient, and reliable operation.

These dependable split systems match Carrier's 40RU or 39 Series indoor-air handlers with the versatile outdoor 38AP condensing units for a wide selection of commercial cooling solutions.

- Split condensing units compatible with ASHRAE 90.1
- Chlorine-free, non-ozone depleting Puron refrigerant (R-410A)
- Coil design flexibility - Microchannel and RTPF coil technology available on all units
- 38APS single-circuit unit has up to 3 rotary scroll compressors
- 38APD unit has up to 6 rotary scroll compressors with 2 independent circuits
- Standard scroll compressor units operate as low as 33% (single circuit) or 13% (dual circuit) of nominal capacity
- Optional digital scroll compressors allow incremental unloading down to 16% (single circuit) or 6% (dual circuit) of nominal capacity for VAV applications. The digital scroll is always on the lead circuit (one per unit)
- Optional high-efficiency, variable-speed condenser fans (38APS025-050 and 38APD025-060) with Greenspeed® intelligence
- Protection against high discharge and low suction refrigerant pressure, and low oil pressure

The 38AP units offer high unit EERs (Energy Efficiency Ratios) up to 11.5 and IPLVs (integrated part load values) up to 16.2.

These units provide greater efficiency than similar units in the marketplace, which translates into year-round operating savings.

The latest safety standards for 38AP units are tested per UL (Underwriters Laboratories) and CSA (Canadian Standards Association) standards and certified by ETL.

## Versatility

The 38AP Series condensing units feature up to 6 compressors and 2 refrigerant circuits, and can be matched with a wide variety of air-handling units. Single circuit condensing units can operate with a single air handler. Dual circuit condensing units can operate with a single air handler or two separate air handlers. Standard units have multiple scroll compressors. A digital scroll option is available. This option of digital control closely matches building loads and allows fine incremental adjustments to the variance in load.

## Durable construction

All 38AP units have weatherized cabinets constructed of heavy-duty galvanized steel prepainted with corrosion-resistant baked enamel. Inside and outside surfaces are protected to ensure long life and good appearance. The durable, galvanized steel, painted components shall withstand 1000 hours in constant neutral salt spray under ASTM (American Society for Testing and Materials) B-117 Standard conditions with a 1 mm scribe per ASTM D1654. After test, painted parts shall show no signs of wrinkling or cracking, no loss of adhesion, and no evidence of blistering, and the mean creepage shall not exceed 1/4 in. (Rating ≥ 4 per ASTM D1654) on either side of the scribe line.

All 38AP units are available with Novation® heat exchangers with microchannel coil technology. The microchannel

heat exchanger (MCHX) coils provide long-term reliability, high performance heat transfer, and significant savings in refrigerant charge. E-coated MCHX as well as e-coated Al/Cu coils can be offered as an option for harsh industrial or coastal conditions, and these coils can withstand an 8,000-hour salt spray test in accordance with the ASTM B-117 Standard. Painted parts shall withstand 1000 hours in constant neutral salt spray under ASTM B117 conditions with a 1 mm scribe per ASTM D1654. After test, painted parts shall show no signs of wrinkling or cracking, no loss of adhesion, no evidence of blistering, and the mean creepage shall not exceed 1/4 in. (Rating ≥ 4 per ASTM D1654) on either side of the scribe line.

## Reliability

The 38AP condensing units feature highly reliable, hermetic scroll compressors. Each 38AP unit is capable of unloading in staging sequence of scroll compressors. Compressors are mounted on rails with vibration isolators to provide quiet operation and reduced component stress.

The 38AP units have single or dual independent circuits; they provide inherent backup capability. Each circuit is also protected by the following safety features:

- Short-cycle protection
- Low superheat protection
- Loss of refrigerant charge protection
- Reverse rotation protection
- Suction and discharge pressure transducers
- High refrigerant pressure switch (discharge)
- Circuit breakers or fuses for short circuit protection of compressors and outdoor fans
- Suction line accumulator for each refrigerant circuit

**38AP condensing units with Greenspeed intelligence** feature a high-efficiency, variable-speed condenser fan option along with fine-tuned *ComfortLink* controls, which together provide premium part load efficiency to facilitate reduced utility costs over the lifespan of the unit. Additionally, the lower sound levels achieved at part load conditions can be very beneficial for sensitive acoustic applications.

**Standard DC link reactor for 38AP units with Greenspeed intelligence** is included in all drives for the fans. The use of this component

## Table of contents

	Page
Features/Benefits . . . . .	2
Model Number Nomenclature . . . . .	4
Physical Data . . . . .	5
Options and Accessories . . . . .	9
Dimensions . . . . .	12
Selection Procedure . . . . .	19
Performance data . . . . .	20
Typical Piping and Wiring . . . . .	21
Electrical Data . . . . .	24
Controls . . . . .	32
Typical Control Wiring Schematics . . . . .	35
Application Data . . . . .	44
Guide Specifications . . . . .	52

mitigates customer concern over electrical system harmonics; therefore, AC line reactors should not be required for applications employing 38AP units with Greenspeed intelligence.

## Easier installation and service

The 38AP units are equipped with hinged control-box access doors, control interface terminal boards, liquid line shutoff valves, and suction line service valves.

## ComfortLink controls

The *ComfortLink* controls communicate in plain English, making it as easy as possible to monitor and control each Gemini™ Select condensing unit while accurately maintaining air temperatures. The large scrolling marquee display acts

as a window into the unit's operation, providing easy-to-read information about chiller performance and over 15 diagnostic functions.

Carrier's 38 Series condensing units' *ComfortLink* controls provide features such as supply air temperature reset, demand limit, 4 to 20 mA input compressor wear minimization and protection, temperature and pressure displays and diagnostic functions. These controls result in higher chiller reliability, simplified training and more productive service calls with correspondingly lower operational and maintenance costs.

Carrier's exclusive accessory handheld *Navigator™* display provides convenience and powerful information in the palm of your hand. The *Navigator* display helps technicians to quickly

diagnose problems and even prevent them from occurring.

All Gemini Select units are ready to be used with the Carrier *Comfort Network®* (CCN) system. A BACnet<sup>1</sup> communication option is also available for the i-Vu<sup>®</sup> Open control system or a BACnet<sup>1</sup> building automation system.

## Seismic certification

A seismic unit modification is available which will result in a unit SDS (seismic design acceleration parameter) level of 2.5 for 38AP025-065 units and 2.1 for 38AP070-130 units.

1. Third-party trademarks and logos are property of their respective owners.

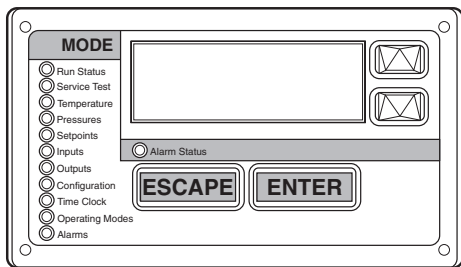

**SCROLLING MARQUEE DISPLAY**

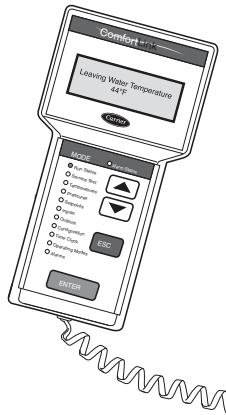

**NAVIGATOR™ DISPLAY**

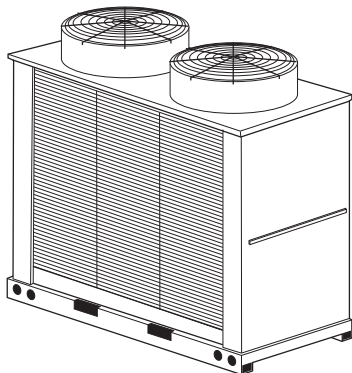

**LOW SOUND OPTION**

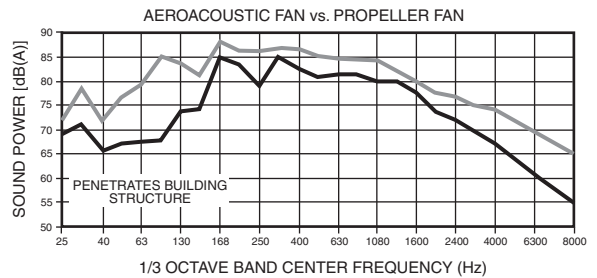

**AEROACOUSTIC FAN VS PROPELLER FAN**

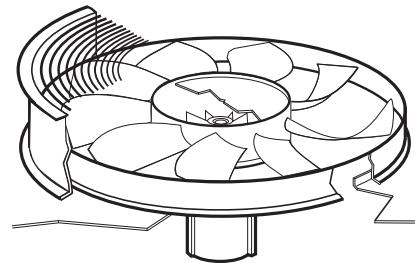

**LOW-NOISE AEROACOUSTIC FAN**

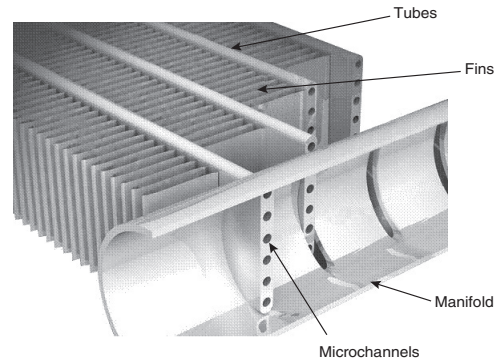

**NOVATION® HEAT EXCHANGER TECHNOLOGY WITH MICROCHANNEL CONDENSER COILS**

# Model number nomenclature

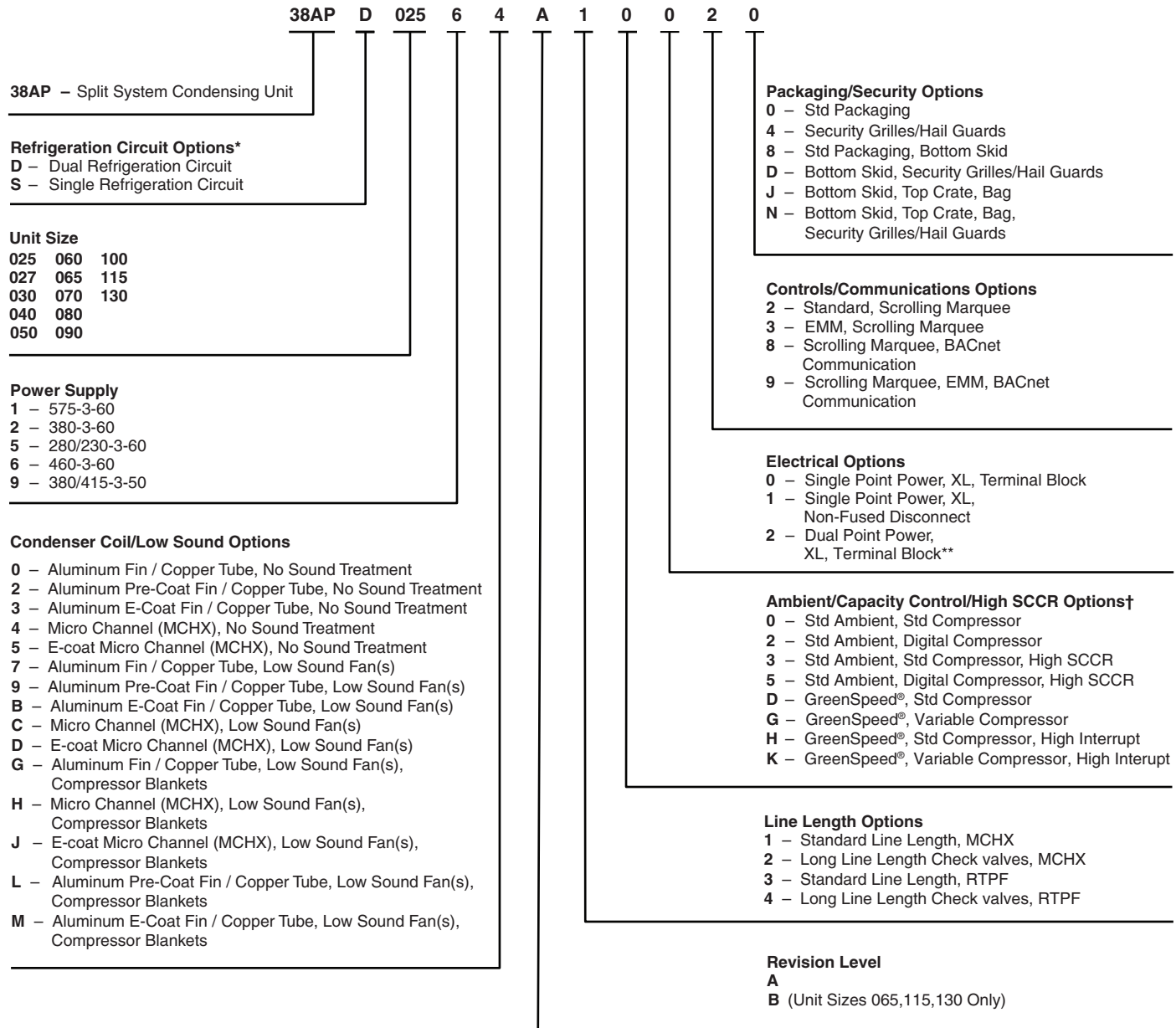

## LEGEND

- EMM** — Energy Management Module
- MCHX** — Microchannel Heat Exchanger
- RTPF** — Round Tube, Plate Fin
- SCCR** — Short Circuit Current Rating
- XL** — Across-the-Line Start

\*38APS units available in sizes 025-050 and 065 only.

†Digital compressor not available on size 065.

\*\*Only available on sizes 115 and 130.

## Quality Assurance

ISO 9001: 2015-certified processes



## 38AP025-050 UNITS — ENGLISH

38AP UNIT SIZE	025		027		030		040		050	
Nominal Capacity, 50/60 Hz (tons)	21/25		23/27		25/30		33/40		42/50	
CIRCUIT	Dual	Single	Dual	Single	Dual	Single	Dual	Single	Dual	Single
<b>Operating Weights (lb)</b>										
Standard MCHX	1095	1077	1258	1240	1264	1246	2094	1968	2120	1977
MCHX, Low Sound Option	1131	1113	1294	1276	1300	1282	2148	2022	2174	2031
Cu-AI RTPF	1168	1150	1347	1329	1353	1335	2273	2147	2299	2156
Cu-AI RTPF, Low Sound Option	1204	1186	1383	1365	1389	1371	2327	2201	2353	2210
<b>REFRIGERANT CHARGE (LB)</b>										
Total MCHX*	25	24	27	26	28	29	38	39	48	48
Circuit A/Circuit B MCHX	12.5/12.5	24/—	13.5/13.5	26/—	14/14	29/—	21/17	39/—	22/26	48/—
Total RTPF*	43	42	49.6	48.5	51.6	51.5	83	83.9	93	92.9
Circuit A/Circuit B RTPF	21.5/21.5	42/—	24.8/24.8	48.5/—	25.3/25.3	51.5/—	43.5/39.5	83.9/—	44.5/48.5	92.9/—
<b>NITROGEN SHIPPING CHARGE</b>	15 psig									
<b>COMPRESSOR hp (Qty) (CKT A/CKT B)</b>	11 (1)/ 11 (1)	11 (2)	13 (1)/ 13 (1)	13 (2)	15 (1)/ 15 (1)	15 (2)	10 (2)/ 8.5 (2)	13 (3)	11 (2)/ 13 (2)	15 (3)
<b>CAPACITY STEPS</b>										
Standard	2	2	2	2	2	2	4	3	4	3
Digital Option	22	22	22	22	22	22	36	27	36	27
<b>CRANKCASE HEATER (W) (each compressor)</b>	90 (60/50 Hz)									
<b>CONDENSER FANS</b>										
Standard	Propeller Type, Axial, Vertical Discharge									
Quantity	2	2	2	2	2	2	3	3	3	3
RPM	1140 (60 Hz), 950 (50 Hz)									
Diameter (in.)	30									
Total Watts (60 Hz)	3300	3300	3300	3300	3300	3300	4200	4200	4200	4200
Total Watts (50 Hz)	1997	1997	1997	1997	1997	1997	2541	2541	2541	2541
Total Airflow (60 Hz) (cfm)	18,500		20,500		20,500		33,300		33,300	
Total Airflow (50 Hz) (cfm)	15,448		17,124		17,124		27,804		27,804	
Low Noise	Plastic Type, Axial, Vertical Discharge									
Quantity	2	2	2	2	2	2	3	3	3	3
RPM	850 (60 Hz), 700 (50 Hz)									
Diameter (in.)	30									
Total Watts (60 Hz)	2750	2750	2750	2750	2750	2750	3500	3500	3500	3500
Total Watts (50 Hz)	1664	1664	1664	1664	1664	1664	2118	2118	2118	2118
Total Airflow (60 Hz) (cfm)	17,500		19,400		19,400		30,501		30,501	
Total Airflow (50 Hz) (cfm)	14,614		16,205		16,205		25,467		25,467	
<b>CONDENSER COIL</b>	MCHX Type									
No. Coils per Circuit	1	1	1	1	1	1	1	2	1	2
sq ft	27.1	27.1	33.9	33.9	33.9	33.9	67.8	67.8	67.8	67.8
<b>TEMPERATURE RELIEF</b>	Fusible Plug on Liquid Lines of Each Circuit — 210°F									
<b>CONNECTIONS (in.) ODF (CKT A/CKT B)</b>										
Suction Line	1-3/8 / 1-3/8	1-5/8	1-3/8 / 1-3/8	1-5/8	1-3/8 / 1-3/8	1-5/8	1-5/8 / 1-5/8	2-1/8	1-5/8 / 1-5/8	2-1/8
Liquid Line	5/8 / 5/8	5/8	5/8 / 5/8	5/8	5/8 / 5/8	7/8	5/8 / 5/8	7/8	5/8 / 5/8	7/8
<b>MAXIMUM HEIGHT FOR 3°F SUBCOOLING (ft)†</b>	75	75	75	75	75	75	75	75	75	75
<b>CAPACITY PER CIRCUIT (%) (CKT A/CKT B)</b>	50/50	100	50/50	100	50/50	100	54/46	100	48/52	100
<b>MINIMUM UNIT CAPACITY (%)</b>										
Standard Compressor	50	50	50	50	50	50	27	33	23	33
Digital Compressor	17	17	17	17	17	17	13	16	11	16

### LEGEND

cfm	—	Cubic Feet per Minute
CKT	—	Circuit
MCHX	—	Microchannel Heat Exchanger
ODF	—	Outside Diameter, Female
RTPF	—	Round Tube Plate Fin

\* Typical operating charge with 25 ft of interconnecting piping. Operating charge is approximate for maximum system capacity. Unit is factory supplied with nitrogen holding charge. Refrigerant charge for dual circuit units is the total for both circuits.

† Maximum vertical separation between evaporator coil and condensing unit if condensing unit is below the evaporator.

### NOTES:

1. Refer to Loading Sequences tables in Application Data section on page 45 or contact Application Engineering for detailed capacity step data.
2. 38AP units with Greenspeed intelligence are available on unit sizes 38APS025-050 and 38APD025-060.

## 38AP060-130 UNITS — ENGLISH

38AP UNIT SIZE	060	065	070	080	090	100	115	130
<b>NOMINAL CAPACITY, 50/60 Hz (tons)</b>	50/60	54/65	58/70	67/80	75/90	83/100	96/115	108/130
<b>CIRCUIT</b>	Dual	Single	Dual	Dual	Dual	Dual	Dual	Dual
<b>Operating Weights (lb)</b>								
Standard MCHX	2227	2505	2450	2610	2835	2844	3211	3353
MCHX, Low Sound Option	2299	2577	2522	2700	2943	2952	3337	3461
Cu-AI RTPF	2405	2975	2920	3290	3530	3539	3966	4492
Cu-AI RTPF, Low Sound Option	2477	3047	2992	3380	3638	3647	4092	4600
<b>REFRIGERANT CHARGE (lb)</b>								
Total MCHX*	56	55	62	75	85	92	101	117
Circuit A/Circuit B MCHX	27/29	—/55	29/33	29/46	39/46	46/46	46/55	46/71
Total RTPF*	101	105	128	157.5	184	191	216.5	249
Circuit A/Circuit B RTPF	49.5/51.5	105/—	62/66	62.0/95.5	88.5/95.5	95.5/95.5	95.5/121.0	95.5/153.5
<b>NITROGEN SHIPPING CHARGE</b>	15 psig							
<b>COMPRESSOR hp (Qty) (CKT A/CKT B)</b>	13 (2)/15 (2)	20 (3)	15 (2)/11 (3)	15 (2)/15 (3)	13 (3)/15 (3)	15 (3)/15 (3)	15 (3)/20 (3)	15 (3)/25 (3)
<b>CAPACITY STEPS</b>								
Standard	4	3	5	5	6	6	6	6
Digital Option	36	—	45	45	54	54	54	54
<b>CRANKCASE HEATER (W) (each compressor)</b>	90 (60/50 Hz)						90 CKT A, 120 CKT B (60/50 Hz)	
<b>CONDENSER FANS</b>								
Standard	Propeller Type, Axial, Vertical Discharge							
Quantity	4	4	4	5	6	6	7	8
RPM	1140 (60 Hz), 950 (50 Hz)							
Diameter (in.)	30							
Total Watts (60 Hz)	6200	6000	6000	7500	9000	9000	10,500	12,000
Total Watts (50 Hz)	3751	3630	3630	4538	5445	5445	6353	7260
Total Airflow (60 Hz) (cfm)	41,000	41,000	41,000	51,250	61,500	61,500	71,750	82,000
Total Airflow (50 Hz) (cfm)	34,247	34,247	34,247	42,809	51,371	51,371	59,933	68,494
Low Noise	Plastic Type, Axial, Vertical Discharge							
Quantity	4	4	4	5	6	6	7	8
RPM	850 (60 Hz), 700 (50 Hz)							
Diameter (in.)	30							
Total Watts (60 Hz)	5200	5000	5000	6250	7500	7500	8750	10,000
Total Watts (50 Hz)	3146	3025	3025	3781	4538	4538	5294	6050
Total Airflow (60 Hz) (cfm)	38,800	38,800	38,800	48,500	58,200	58,200	67,900	77,600
Total Airflow (50 Hz) (cfm)	32,410	32,410	32,410	40,512	48,614	48,614	56,717	64,819
<b>CONDENSER COIL</b>	MCHX Type							
No. Coils per Circuit	1	3	2	2 to 3	3	3	3 to 4	3 to 5
sq ft	67.8	99.6	99.6	124.5	149.4	149.4	174.3	199.2
<b>TEMPERATURE RELIEF</b>	Fusible Plug on Liquid Lines of Each Circuit — 210°F							
<b>CONNECTIONS (in.) ODF (CKT A/CKT B)</b>								
Suction Line	1-5/8 / 1-5/8	2-5/8	1-5/8 / 2-1/8	1-5/8 / 2-1/8	2-1/8 / 2-1/8	2-1/8 / 2-1/8	2-1/8 / 2-5/8	2-1/8 / 2-5/8
Liquid Line	5/8 / 5/8	7/8	7/8 / 7/8	7/8 / 7/8	7/8 / 7/8	7/8 / 7/8	7/8 / 7/8	7/8 / 1-1/8
<b>MAXIMUM HEIGHT FOR 3°F SUBCOOLING (ft)†</b>	75	75	75	75	75	75	75	75
<b>CAPACITY PER CIRCUIT (%) (CKT A/CKT B)</b>	46/54	100	47/53	40/60	46/54	50/50	44/56	38/62
<b>MINIMUM UNIT CAPACITY (%)</b>								
Standard Compressor	23	33	24	20	15	17	14	13
Digital Compressor	11	—	11	9	7	8	7	6

### LEGEND

<b>cfm</b>	—	Cubic Feet per Minute
<b>CKT</b>	—	Circuit
<b>MCHX</b>	—	Microchannel Heat Exchanger
<b>ODF</b>	—	Outside Diameter, Female
<b>RTPF</b>	—	Round Tube, Plate Fin

\* Typical operating charge with 25 ft of interconnecting piping. Operating charge is approximate for maximum system capacity. Unit is factory supplied with nitrogen holding charge. Refrigerant charge for dual circuit units is the total for both circuits.

† Maximum vertical separation between evaporator coil and condensing unit if condensing unit is below the evaporator.

### NOTES:

1. Refer to Loading Sequences tables in Application Data section on page 45 or contact Application Engineering for detailed capacity step data.
2. 38AP units with Greenspeed intelligence are available on unit sizes 38APS025-050 and 38APD025-060.

# Physical data (cont)



## 38AP025-050 UNITS — SI

38AP UNIT SIZES	025		027		030		040		050	
NOMINAL CAPACITY 50/60 Hz (kW)	73/88		79/95		88/105		117/141		146/176	
CIRCUIT	Dual	Single	Dual	Single	Dual	Single	Dual	Single	Dual	Single
<b>OPERATING WEIGHTS (kg)</b>										
Standard MCHX	497	489	571	562	573	565	950	893	961	897
MCHX, Low Sound Option	513	505	587	579	590	582	974	917	986	921
Cu-AI RTPF	531	522	611	603	613	605	1031	974	1042	978
Cu-AI RTPF, Low Sound Option	547	538	627	620	630	622	1055	998	1067	1002
<b>REFRIGERANT CHARGE (kg)</b>										
Total MCHX*	11.5	11	12.5	12	14	13	18	18	22	22
Circuit A/Circuit B MCHX	6/6	11/—	6.5/6.5	12/—	7/7	13/—	10/8	18/—	10/12	22/—
Total RTPF*	19.5	19	22.5	22	22.9	23.4	37.6	38	42.1	42.1
Circuit A/Circuit B RTPF	10/10	19/—	11.5/11.5	22/—	11.5/11.5	23.4/—	19.7/17.9	38/—	20.0/22	42.1/—
<b>NITROGEN SHIPPING CHARGE</b>	1.03 bar									
<b>COMPRESSOR kW (Qty) (CKT A/CKT B)</b>	8.2 (1)/ 8.2 (1)	8.2 (2)	9.7 (1)/ 9.7 (1)	9.7 (2)	11.2 (1)/ 11.2 (1)	11.2 (2)	7.5 (2)/ 6.3 (2)	9.7 (3)	8.2 (2)/ 9.7 (2)	11.2 (3)
<b>CAPACITY STEPS</b>										
Standard	2	2	2	2	2	2	4	3	4	3
Digital Option	22	22	22	22	22	22	36	27	36	27
<b>CRANKCASE HEATER (W) (each compressor)</b>	90 (60/50 Hz)									
<b>CONDENSER FANS</b>	Propeller Type, Axial, Vertical Discharge									
Quantity	2	2	2	2	2	2	3	3	3	3
r/s	19 (60 Hz), 16 (50 Hz)									
Diameter (mm)	762									
Total Watts (60 Hz)	3300	3300	3300	3300	3300	3300	4200	4200	4200	4200
Total Watts (50 Hz)	1997	1997	1997	1997	1997	1997	2541	2541	2541	2541
Total Airflow (60 Hz) (L/s)	8731		9675		9675		15 716		15 716	
Total Airflow (50 Hz) (L/s)	7291		8081		8081		13 122		13 122	
<b>Low Noise</b>	Plastic Type, Axial, Vertical Discharge									
Quantity	2	2	2	2	2	2	3	3	3	3
r/s	14 (60 Hz), 12 (50 Hz)									
Diameter (mm)	762									
Total Watts (60 Hz)	2750	2750	2750	2750	2750	2750	3500	3500	3500	3500
Total Watts (50 Hz)	1664	1664	1664	1664	1664	1664	2118	2118	2118	2118
Total Airflow (60 Hz) (L/s)	8259		9156		9156		14 395		14 395	
Total Airflow (50 Hz) (L/s)	6897		7648		7648		12 019		12 019	
<b>CONDENSER COIL</b>	MCHX Type									
No. Coils per Circuit	1	1	1	1	1	1	1	2	1	2
sq m	2.5	2.5	3.1	3.1	3.1	3.1	6.3	6.3	6.3	6.3
<b>TEMPERATURE RELIEF</b>	Fusible Plug on Liquid Lines of Each Circuit — 99°C									
<b>CONNECTIONS (in.) ODF (CKT A/CKT B)</b>										
Suction Line	1-3/8 / 1-3/8	1-5/8	1-3/8 / 1-3/8	1-5/8	1-3/8 / 1-3/8	1-5/8	1-5/8 / 1-5/8	2-1/8	1-5/8 / 1-5/8	2-1/8
Liquid Line	5/8 / 5/8	5/8	5/8 / 5/8	5/8	5/8 / 5/8	7/8	5/8 / 5/8	7/8	5/8 / 5/8	7/8
<b>MAXIMUM HEIGHT FOR 1.7°C SUBCOOLING (m)†</b>	23	23	23	23	23	23	23	23	23	23
<b>CAPACITY PER CIRCUIT (%) (CKT A/CKT B)</b>	50/50	100	50/50	100	50/50	100	54/46	100	48/52	100
<b>MINIMUM UNIT CAPACITY (%)</b>										
Standard Compressor	50	50	50	50	50	50	27	33	23	33
Digital Compressor	17	17	17	17	17	17	13	16	11	16

### LEGEND

CKT	—	Circuit
L/s	—	Liters per Second
MCHX	—	Microchannel Heat Exchanger
ODF	—	Outside Diameter, Female
RTPF	—	Round Tube, Plate Fin

\* Typical operating charge with 7.62 m of interconnecting piping. Operating charge is approximate for maximum system capacity. Unit is factory supplied with nitrogen holding charge. Refrigerant charge for dual circuit units is the total for both circuits.

† Maximum vertical separation between evaporator coil and condensing unit if condensing unit is below the evaporator.

### NOTES:

1. Refer to Loading Sequences tables in Application Data section on page 45 or contact Application Engineering for detailed capacity step data.
2. 38AP units with Greenspeed intelligence are available on unit sizes 38APS025-050 and 38APD025-060.

## 38AP060-130 UNITS — SI

38AP UNIT SIZES	060	065	070	080	090	100	115	130
Nominal Capacity 50/60 Hz (kW)	176/211	190/228	205/246	234/281	264/316	293/351	337/404	381/457
CIRCUIT	Dual	Single	Dual	Dual	Dual	Dual	Dual	Dual
Operating Weights (kg)								
Standard MCHX	1010	1136	1111	1184	1286	1290	1456	1521
MCHX, Low Sound Option	1043	1169	1144	1225	1335	1339	1514	1570
Cu-AI RTPF	1090	1350	1324	1492	1601	1605	1799	2038
Cu-AI RTPF, Low Sound Option	1123	1382	1357	1533	1650	1654	1856	2087
Refrigerant Charge (kg)								
Total MCHX*	25	25	28	34	39	42	46	53
Circuit A/Circuit B MCHX	12/13	—/25	13/15	13/21	18/21	21/21	21/25	21/32
Total RTPF*	45.8	47.6	58	71.4	83.4	86.6	98.2	113
Circuit A/Circuit B RTPF	22.4/23.4	47.6/—	28.1/29.9	28.1/43.3	40.1/43.3	43.3/43.3	43.3/54.9	43.3/69.6
NITROGEN SHIPPING CHARGE	1.03 bar							
Compressor kW (Qty) (CKT A/CKT B)	9.7 (2)/ 11.2 (2)	15.0 (3)	11.2 (2)/ 8.2 (3)	11.2 (2)/ 11.2 (3)	9.7 (3)/ 11.2 (3)	11.2 (3)/ 11.2 (3)	11.2 (3)/ 15.0 (3)	11.2 (3)/ 18.6 (3)
CAPACITY STEPS								
Standard	4	3	5	5	6	6	6	6
Digital Option	36	—	45	45	54	54	54	54
Crankcase Heater (W) (each compressor)	90 (60/50 Hz)						90 CKT A, 120 CKT B (60/50 Hz)	
CONDENSER FANS								
Standard	Propeller Type, Axial, Vertical Discharge							
Quantity	4	4	4	5	6	6	7	8
r/s	19 (60 Hz), 16 (50 Hz)							
Diameter (mm)	762							
Total Watts (60 Hz)	6200	6000	6000	7500	9000	9000	10 500	12 000
Total Watts (50 Hz)	3751	3630	3630	4538	5445	5445	6353	7260
Total Airflow (60 Hz) (L/s)	19 350	19 350	19 350	24 187	29 025	29 025	33 862	38 700
Total Airflow (50 Hz) (L/s)	16 163	16 163	16 163	20 204	24 244	24 244	28 285	32 326
Low Noise	Plastic Type, Axial, Vertical Discharge							
Quantity	4	4	4	5	6	6	7	8
r/s	14 (60 Hz), 12 (50 Hz)							
Diameter (mm)	762							
Total Watts (60 Hz)	5200	5000	5000	6250	7500	7500	8750	10 000
Total Watts (50 Hz)	3146	3025	3025	3781	4538	4538	5294	6050
Total Airflow (60 Hz) (L/s)	18 312	18 312	18 312	22 889	27 467	27 467	32 045	36 623
Total Airflow (50 Hz) (L/s)	15 296	15 296	15 296	19 120	22 943	22 943	26 767	30 591
Condenser Coil	MCHX Type							
No. Coils per Circuit	1	3	2	2 to 3	3	3	3 to 4	3 to 5
sq m	6.3	6.9	9.3	11.6	13.9	13.9	16.2	18.5
Temperature Relief	Fusible Plug on Liquid Lines of Each Circuit — 99°C							
Connections (in.) ODF (CKT A/CKT B)								
Suction Line	1-5/8 / 1-5/8	2-5/8	1-5/8 / 2-1/8	1-5/8 / 2-1/8	2-1/8 / 2-1/8	2-1/8 / 2-1/8	2-1/8 / 2-5/8	2-1/8 / 2-5/8
Liquid Line	5/8 / 5/8	7/8	7/8 / 7/8	7/8 / 7/8	7/8 / 7/8	7/8 / 7/8	7/8 / 7/8	7/8 / 1-1/8
Maximum Height for 1.7°C subcooling (m)†	23	23	23	23	23	23	23	23
CAPACITY per Circuit (%) (CKT A/CKT B)	46/54	100	47/53	40/60	46/54	50/50	44/56	38/62
Minimum UNIT Capacity (%)								
Standard Compressor	23	33	24	20	15	17	14	13
Digital Compressor	11	—	11	9	7	8	7	6

### LEGEND

CKT	—	Circuit
L/s	—	Liters per Second
MCHX	—	Microchannel Heat Exchanger
ODF	—	Outside Diameter, Female
RTPF	—	Round Tube, Plate Fin

\* Typical operating charge with 7.62 m of interconnecting piping. Operating charge is approximate for maximum system capacity. Unit is factory supplied with nitrogen holding charge. Refrigerant charge for dual circuit units is the total for both circuits.

† Maximum vertical separation between evaporator coil and condensing unit if condensing unit is below the evaporator.

### NOTES:

1. Refer to Loading Sequences tables in Application Data section on page 45 or contact Application Engineering for detailed capacity step data.
2. 38AP units with Greenspeed intelligence are available on unit sizes 38APS025-050 and 38APD025-060.



# Options and accessories



ITEM	FACTORY-INSTALLED OPTION	FIELD-INSTALLED ACCESSORY
<b>Condenser Coil/Low Sound Options</b>		
E-Coated MCHX	X	
Aluminum Fin/Copper Tube	X	
Aluminum Pre-Coat Fin/Copper Tube	X	
Aluminum E-Coat Fin/Copper Tube	X	
Low Sound Fan(s)	X	X
Low Sound Compressor Blankets	X	X
Vibration Isolation Pads		X
<b>Line Length Options</b>		
Long Line Length Check Valve	X	X
<b>Ambient/Capacity Control/High SCCR Options</b>		
Digital Compressor*	X	
High Short Circuit Current Rating (SCCR)	X	
High-Efficiency Variable Condenser Fans (available on unit sizes 38APS025-050 and 38APD025-060)	X	
<b>Electrical Options</b>		
Dual Point Power (sizes 115 and 130 only)	X	
Non-Fused Disconnect	X	
<b>Controls/Communications Options</b>		
Navigator™ Display		X
Touch Pilot™ Display		X
EMM	X	X
BACnet Communication	X	
BACnet Translator Control		X
LON Translator Control		X
<b>Packaging/Security Options</b>		
Bottom Skid	X	
Top Crate, Bag	X	
Security Grilles/Hail Guards	X	X
Wind Baffles		X

## LEGEND

**E-Coated** — Epoxy Coating Applied to Entire Coil Assembly  
**EMM** — Energy Management Module  
**LON** — Local Operating Network  
**MCHX** — Microchannel Heat Exchanger  
**SCCR** — Short Circuit Current Rating

\* Digital compressors provide incremental unloading from full capacity down to a minimum value. Not available on size 065 unit.

## NOTES:

1. Std SCCR (short circuit current rating) (5 kA).
2. High SCCR 460-v and 380/415-v (65 kA), 208/230-v (65 kA), 575-v (25 kA).

## Factory-installed options

### Condenser coil

Options are available to match coil construction to the site conditions for the best durability. Refer to the Condenser Coil Corrosion Protection Options table on page 11 or the appropriate selection guide for more information.

### Low sound fans

Fans provide a specially designed system of fan propellers and stacks that reduce sound without reducing unit performance. The factory-installed fan option is compatible with the Motormaster® V option. Low sound fans are also available as field-installed accessory.

### Low sound compressor blankets

Blankets reduce unit sound levels by providing an acoustic blanket on each compressor. Compressor blankets are also available as field-installed accessory.

### Security grilles/hail guards

Guard and grilles consist of louvered, sheet metal panels which securely fasten to the unit and provide condenser coil protection against hail and physical damage. Security grilles/hail guards are also available as field-installed accessories.

### Long line length check valves

Check valves are required for liquid line installation on all linear line length applications of more than 100 ft (30.5 m). For any 025-030 size dual-circuit unit application where evaporator is located higher than the condensing unit, check valves are required for linear line length above 55 ft (16.8 m). The check valve option prevents charge migration to compressor. As an option, the check valves are shipped with the unit but require field installation. Check valves are also available as field-installed accessories shipped separately from the unit.

### Digital compressor control

Digital compressors allow incremental unloading for a closer match to building load, improved compressor reliability in the reduced compressor cycling, and improved efficiency as compared to hot gas bypass and other modulating methods. Refer to Loading Sequences table in Application Data section on page 45. Digital compressor option is not available on unit size 065.

**High-efficiency variable condenser fans** control the speed of all fans for improvement in part load efficiency and sound levels. Additionally, high-efficiency variable condenser fans maintain head pressure control down to -20°F (-29°C) ambient temperature with the use of wind baffles. Varying the speed of all fans on a circuit to a prescribed speed provides accurate head pressure control to the most efficient point while achieving optimum usage of the coils to accomplish excellent part load efficiency. These fans are the key component of the 38AP condensing unit with Greenspeed® intelligence. This option is available for unit sizes 38APS025-050 and 38APD025-060.

## High short circuit current rating (SCCR) interrupt

High SCCR interrupt provides a short circuit current rating protection for the unit up to 65 kA on 460-v, 380/415-v, and 208/230-v units or 25 kA on 575-v units. The high SCCR option is strictly in conjunction with a non-fused disconnect and only with single-point power connection. See the High SCCR Availability table.

### HIGH SCCR AVAILABILITY

UNIT VOLTAGE	38AP UNIT SIZE	
	025-070, 080-130	
	NON-FUSED DISCONNECT	TERMINAL BLOCK
208/230-3-60	X	—
380-3-60	X	—
380/415-3-50	X	—
460-3-60	X	—
575-3-60	X	—

## Dual point power connection

This option is provided with terminal blocks for size 115 and 130 units.

### Non-fused disconnect

Non-fused disconnect includes factory-installed non-fused disconnect capability for power and control located at the unit.

### Packaging options

This option includes bottom skid with standard coil protection and bottom skid, top crate with bag. Standard coil protection is also included on all unit packaging.

### Energy management module (EMM)

This module provides energy management capabilities to minimize condensing unit energy consumption. The EMM is also available as a field-installed accessory.

### BACnet communication option

This option provides factory-installed communication capability with a BACnet MS/TP network. Allows integration with i-Vu® Open control system or a BACnet building automation system.

## Field-installed accessories

### Vibration isolation pads

Isolation pads reduce vibration transmission from the compressor through the floor and into the conditioned space. The neoprene isolator pads measure 1/4 in. thick (24 in. x 3 in.).

### Long line length check valves

Check valves are required for liquid line installation on all linear line length applications of more than 100 ft (30.5 m). For any 025-030 size dual-circuit unit application where evaporator is located higher than the condensing unit, check valves are required for linear line length above 55 ft (16.8 m). The check valve option prevents charge migration to compressor. Field installation is required. Check valves are also available as an option that ships with the unit.

## Navigator™ display module

The Navigator display module provides a portable, hand held display module for convenient access to unit status, operation, configuration and troubleshooting diagnostics capability. The 4-line, 80-character LCD (liquid crystal display) display provides clear language information in English, French, Spanish or Portuguese. The weatherproof enclosure and industrial grade extension cord make the Navigator module ideally suited for outdoor applications. Magnets located on the back of the module allow attachment to any sheet metal component for hands-free operation.

## Energy management module

The module provides energy management capabilities to minimize condensing unit energy consumption. The EMM is also available as a factory-installed option.

## BACnet translator control

This option provides an interface between the unit and a BACnet Local Area Network (LAN, i.e., MS/TP EIA-485).

## LON (local operating network) translator control

LON control provides an interface between the unit and a local operating network (i.e., LonWorks<sup>1</sup> FT-10A ANSI/EIA-709.1).

## Touch Pilot™ display

Touch Pilot is a cost-effective, touch-screen, remote-mount device.

## Low sound compressor blankets

Low sound compressor blankets reduce unit sound levels by providing an acoustic blanket on each compressor. Compressor blankets are also available as factory installed option.

## Security grilles/hail guards

Security grilles/hail guards consist of louvered, sheet metal panels which securely fasten to the unit and provide condenser coil protection against hail and physical damage. Security grilles/hail guards are also available as a factory-installed option.

## Low sound fans

Low sound fans provide a specially designed system of fan propellers and stacks that reduce sound without reducing unit performance. The field-installed fan accessory is compatible with the Motormaster V option. Low sound fans are also available as factory-installed option.

## Wind baffles

Wind baffles facilitate operation down to -20°F (-29°C) when used in conjunction with high-efficiency variable condenser fans. Use of wind baffles alone, without the use of high-efficiency variable condenser fans, does not reduce the minimum standard ambient values. Wind baffles are available on unit sizes 025-060.

1. Third-party trademarks and logos are property of their respective owners.

## CONDENSER COIL CORROSION PROTECTION OPTIONS

ENVIRO-SHIELD™ OPTION*	ENVIRONMENT				
	Standard	Mild Coastal	Severe Coastal	Industrial	Combined Industrial/Coastal
Novation® Heat Exchanger (Standard)	See NACO Packaged Chiller Builder				
Novation® Heat Exchanger, E-Coat	See NACO Packaged Chiller Builder				
AL Fins	X				
AL Fins, E-coat			X	X	X
AL Fins, Pre-coated		X			

### LEGEND

**AL** — Aluminum  
**NACO** — North American Commercial Operations

\* See NACO Packaged Chiller Builder for details. Additional corrosion protection is available. For Novation or round tube/plate fin (RTPF) heat exchangers, see selection guide "Environmental Corrosion Protection" (Publication 04-581061-01).

## 38AP025-030 UNITS, STANDARD AND LOW SOUND

THIS DOCUMENT IS THE PROPERTY OF CARRIER CORPORATION AND ITS CONTENTS WILL NOT BE DISCLOSED OR USED WITHOUT CARRIER CORPORATION'S WRITTEN CONSENT.

UNIT	CENTER OF GRAVITY		UNIT HEIGHT H	POWER ENTRY P	SERVICE VALVE CONNECTIONS	
	X	Y			SUCTION	LIQUID
38AP025	17.8 (452)	36.9 (937)	61.0 (1549)	24.9 (632)	1-5/8 (41)	5/8 (16)
38AP025	17.8 (452)	37.0 (940)			1-3/8 (33)	5/8 (16)
38AP027	18.2 (462)	37.6 (955)	73.1 (1857)	36.9 (937)	1-5/8 (41)	5/8 (16)
38AP027	18.2 (462)	37.6 (955)			1-3/8 (33)	5/8 (16)
38AP030	18.2 (462)	37.5 (953)	66.5 (1689)	24.9 (632)	1-5/8 (41)	5/8 (16)
38AP030	18.2 (462)	37.6 (955)			1-3/8 (33)	5/8 (16)
38AP025	17.8 (452)	36.9 (937)	66.5 (1689)	24.9 (632)	1-5/8 (41)	5/8 (16)
38AP025	17.8 (452)	37.0 (940)			1-3/8 (33)	5/8 (16)
38AP027	18.2 (462)	37.6 (955)	76.6 (1956)	36.9 (937)	1-5/8 (41)	5/8 (16)
38AP027	18.2 (462)	37.5 (953)			1-3/8 (33)	5/8 (16)
38AP030	18.2 (462)	37.6 (955)			1-5/8 (41)	5/8 (16)
38AP030	18.2 (462)	37.6 (955)			1-3/8 (33)	5/8 (16)

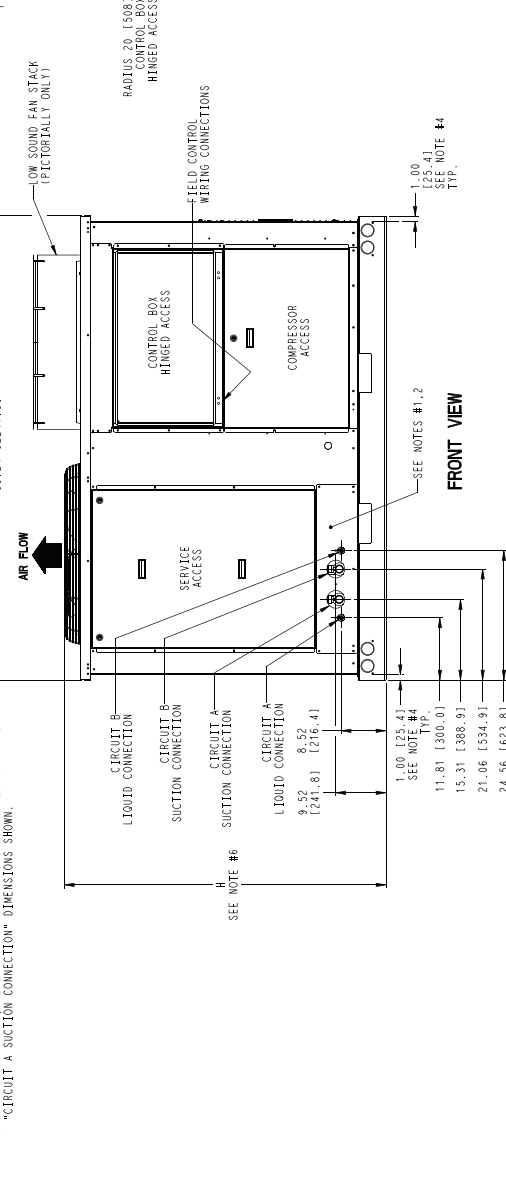
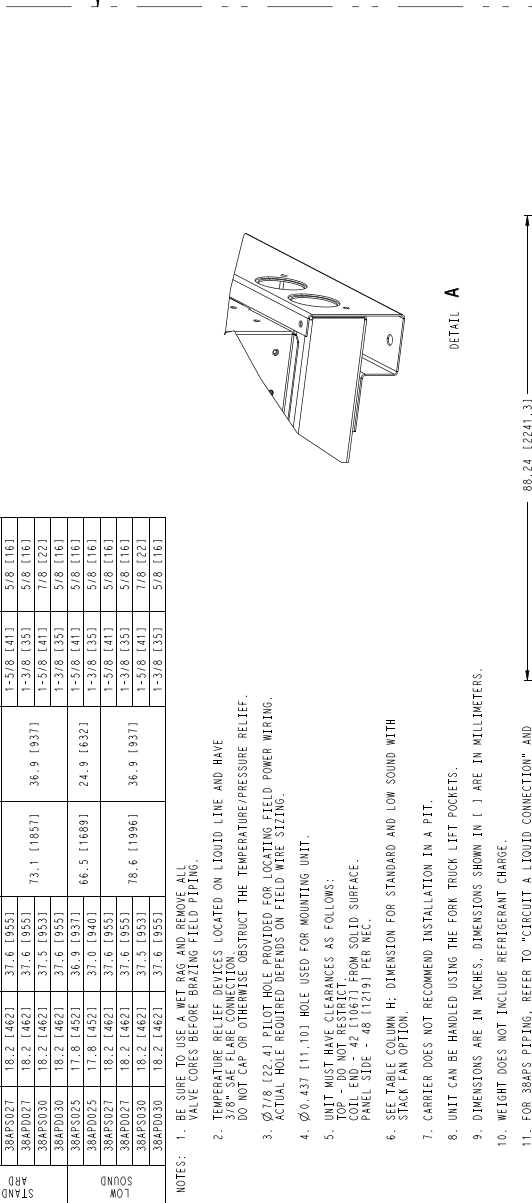
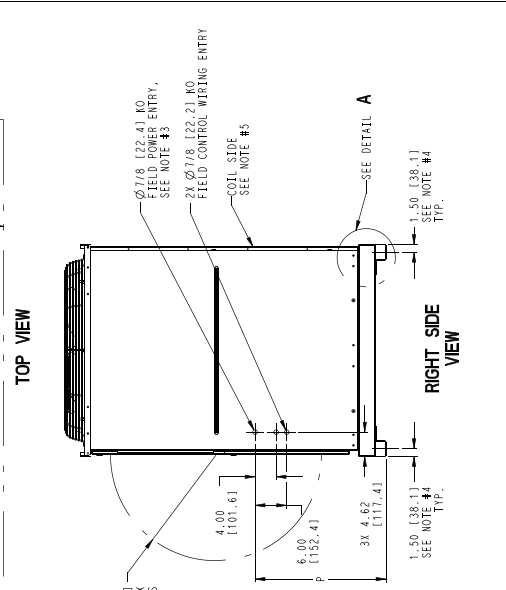
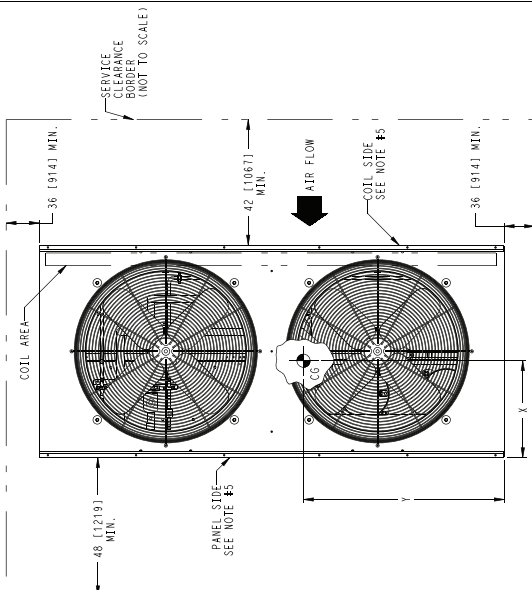

- NOTES: 1. BE SURE TO USE A NET BAG AND REMOVE ALL VALVE CORES BEFORE BRAZING FIELD PIPING.
2. TEMPERATURE RELIEF DEVICES LOCATED ON LIQUID LINE AND HAVE 5/8" SAE FLARE CONNECTION. DO NOT CAP OR OTHERWISE OBSTRUCT THE TEMPERATURE/PRESSURE RELIEF.
3. Ø7/8 (22.4) PILOT HOLE PROVIDED FOR LOCATING FIELD POWER WIRING. ACTUAL HOLE REQUIRED DEPENDS ON FIELD WIRE SIZING.
4. Ø0.437 (11.1) HOLE USED FOR MOUNTING UNIT.
5. UNIT MUST HAVE CLEARANCES AS FOLLOWS:  
 COIL END - 42 (1067) FROM SOLID SURFACE.  
 COIL SIDE - 48 (1219) PER NEC.  
 PANEL SIDE - 36 (914) MIN.
6. SEE TABLE COLUMN H: DIMENSION FOR STANDARD AND LOW SOUND WITH STACK FAN OPTION.
7. CARRIER DOES NOT RECOMMEND INSTALLATION IN A PIT.
8. UNIT CAN BE HANDLED USING THE FORK TRUCK LIFT POCKETS.
9. DIMENSIONS ARE IN INCHES. DIMENSIONS SHOWN IN ( ) ARE IN MILLIMETERS.
10. WEIGHT DOES NOT INCLUDE REFRIGERANT CHARGE.
11. FOR 38AP'S PIPING, REFER TO "CIRCUIT A LIQUID CONNECTION" AND "CIRCUIT A SUCTION CONNECTION" DIMENSIONS SHOWN.

ITC CLASSIFICATION	SHEET	DATE	SUBREVISED	REV	UNIT ASSY	REV
U.S. - ECCN:EAR99	1 OF 2	12/14/21	02/28/19	6	38AP025-030 UNIT ASSY	H
					38AP555555	





## 38AP025-030 UNITS, GREENSPEED

UNIT	STD. UNIT WEIGHT		CENTER OF GRAVITY		UNIT HEIGHT H	POWER ENTRY P	SERVICE VALVE CONNECTIONS	
	LBS.	KG.	X	Y			SUCTION	LIQUID
38AP025	1077	489	17.8 (452)	36.8 (937)	61.0 (1549)	24.9 (632)	1-5/8 (41)	5/8 (16)
38AP025	1095	497	17.8 (452)	37.0 (940)			1-3/8 (35)	5/8 (16)
38AP027	1240	563	18.2 (462)	37.6 (955)			1-5/8 (41)	5/8 (16)
38AP027	1258	571	18.2 (462)	37.6 (955)	73.1 (1857)	36.9 (937)	1-3/8 (35)	5/8 (16)
38AP030	1246	565	18.2 (462)	37.5 (953)			1-5/8 (41)	7/8 (22)
38AP030	1264	573	18.2 (462)	37.6 (955)			1-3/8 (35)	5/8 (16)

- NOTES:
- BE SURE TO USE A WET RAG AND REMOVE ALL VALVE CORES BEFORE BRAZING FIELD PIPING.
  - TEMPERATURE RELIEF DEVICES LOCATED ON LIQUID LINE AND HAVE TO NOT CAP OR OTHERWISE OBSTRUCT THE TEMPERATURE/PRESSURE RELIEF.
  - Ø 7/8 (22.4) PILOT HOLE PROVIDED FOR LOCATING FIELD POWER WIRING. ACTUAL HOLE REQUIRED DEPENDS ON FIELD WIRE SIZING.
  - Ø 0.437 (11.101) HOLE USED FOR MOUNTING UNIT.
  - UNIT MUST HAVE CLEARANCES AS FOLLOWS:  
TOP - 10.0 (254) MIN. RESTRICTED COIL END - 42 (1067) FROM SOLID SURFACE. PANEL SIDE - 48 (1219) PER NEC.
  - SEE TABLE COLUMN H: DIMENSION FOR STANDARD AND LOW SOUND WITH STACK FAN OPTION.
  - CARRIER DOES NOT RECOMMEND INSTALLATION IN A PIT.
  - UNIT CAN BE HANDLED USING THE FORK TRUCK LIFT POCKETS.
  - DIMENSIONS ARE IN INCHES. DIMENSIONS SHOWN IN ( ) ARE IN MILLIMETERS.
  - WEIGHT DOES NOT INCLUDE REFRIGERANT CHARGE.
  - FOR 38AP PIPING, REFER TO "CIRCUIT A LIQUID CONNECTION" AND "CIRCUIT A SUCTION CONNECTION" DIMENSIONS SHOWN.

THIS DOCUMENT IS THE PROPERTY OF CARRIER CORPORATION AND IS NOT TO BE REPRODUCED OR TRANSMITTED IN ANY FORM OR BY ANY MEANS, ELECTRONIC OR MECHANICAL, WITHOUT THE WRITTEN CONSENT OF CARRIER CORPORATION. PERMISSION OF THESE DRAWINGS OR DOCUMENTS DOES NOT CONSTITUTE PART PERFORMANCE OR WARRANTY OF CARRIER CORPORATION.

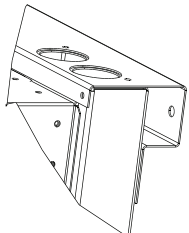
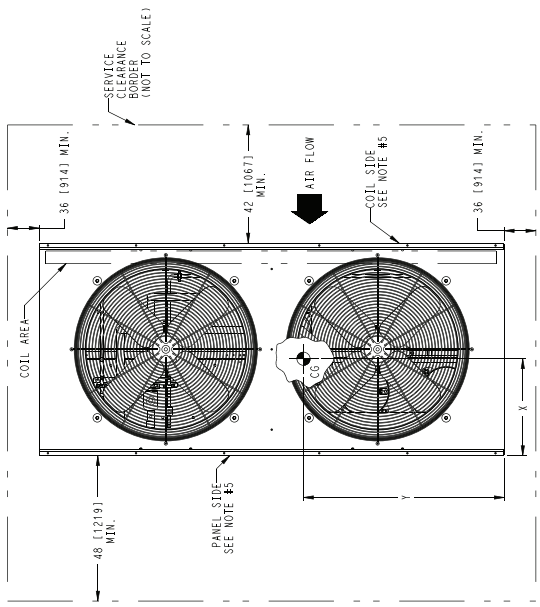

DETAIL A

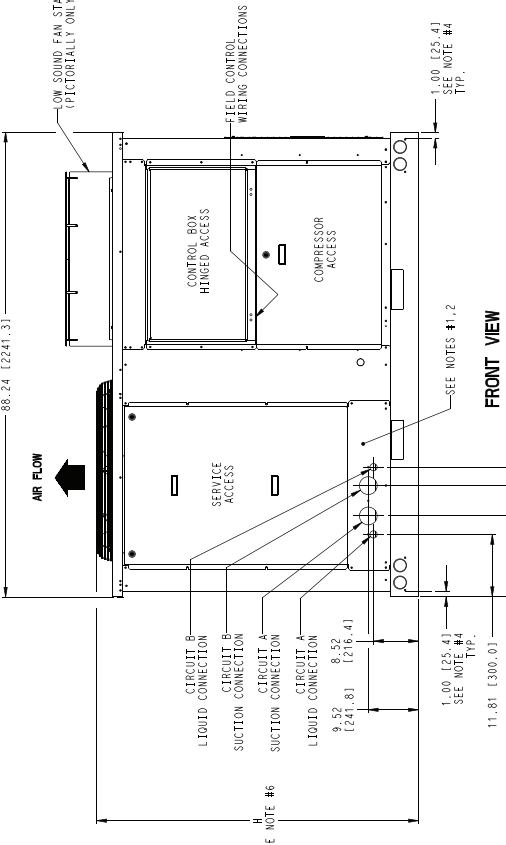
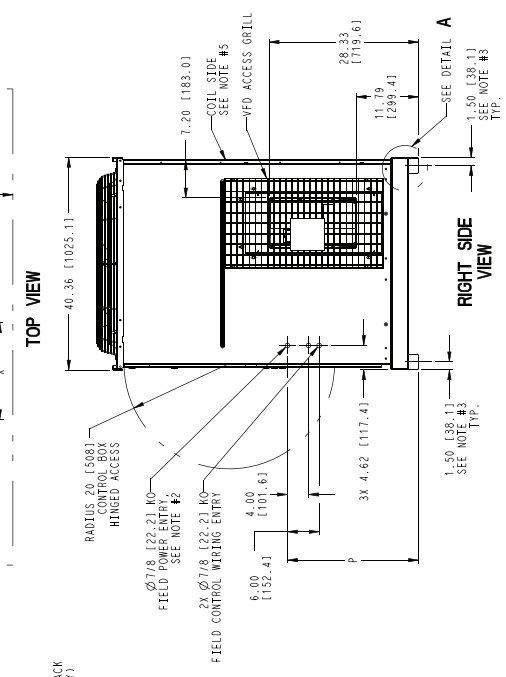

REV	H	38AP555555
SUBREV	02/28/19	38AP025-030W/ GREENSPEED OPTION
DATE	12/14/21	
SHEET	2 OF 2	
U.S. ECCN	EAR99	





## 38AP040-060 UNITS, GREENSPEED

THIS DOCUMENT IS THE PROPERTY OF CARRIER CORPORATION AND IS TO BE USED ONLY FOR THE SPECIFIC PROJECT AND APPLICATION FOR WHICH IT WAS SUBMITTED. IT IS NOT TO BE REPRODUCED OR TRANSMITTED IN ANY FORM OR BY ANY MEANS, ELECTRONIC OR MECHANICAL, INCLUDING PHOTOCOPYING, RECORDING, OR BY ANY INFORMATION STORAGE AND RETRIEVAL SYSTEM, WITHOUT THE WRITTEN CONSENT OF CARRIER CORPORATION.



NOTES: 1. BE SURE TO USE A WET BAG AND REMOVE ALL VALVE CORES BEFORE BRAZING FIELD PIPING.  
 2. TEMPERATURE RELIEF DEVICES LOCATED ON LIQUID LINE AND HAVE A 3/8" SAE FLARE CONNECTION.  
 3. DO NOT CAP OR OTHERWISE OBSTRUCT THE TEMPERATURE/PRESSURE RELIEF.  
 4. ACTUAL HOLE REQUIRED DEPENDS ON FIELD WIRE SIZING.  
 5. UNIT MUST HAVE CLEARANCES AS FOLLOWS:  
 TOP - DO NOT RESTRICT FROM SOLID SURFACE.  
 COIL END - 42 (1067) MIN.  
 PANEL SIDE - 48 (1219) MIN.  
 6. SEE TABLE COLUMN H; DIMENSION FOR STANDARD AND LOW SOUND WITH STACK FAN OPTION.  
 7. CARRIER DOES NOT RECOMMEND INSTALLATION IN A PIT.  
 8. UNIT CAN BE HANDLED USING THE FORK TRUCK LIFT POCKETS.  
 9. DIMENSIONS ARE IN INCHES, DIMENSIONS SHOWN IN ( ) ARE IN MILLIMETERS.  
 10. SIZES 040 AND 050 UNITS HAVE 3 CONDENSER FANS; SIZE 060 UNITS HAVE 4 CONDENSER FANS.  
 11. WEIGHT DOES NOT INCLUDE REFRIGERANT CHARGE.  
 12. FOR 38AP'S PIPING-REFER TO 'CIRCUIT A LIQUID CONNECTION' AND 'CIRCUIT A SUCTION CONNECTION' DIMENSIONS SHOWN.

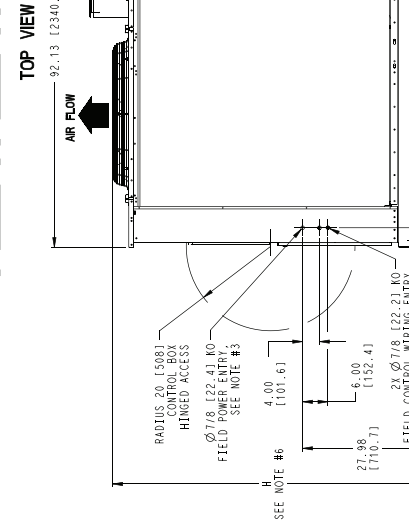
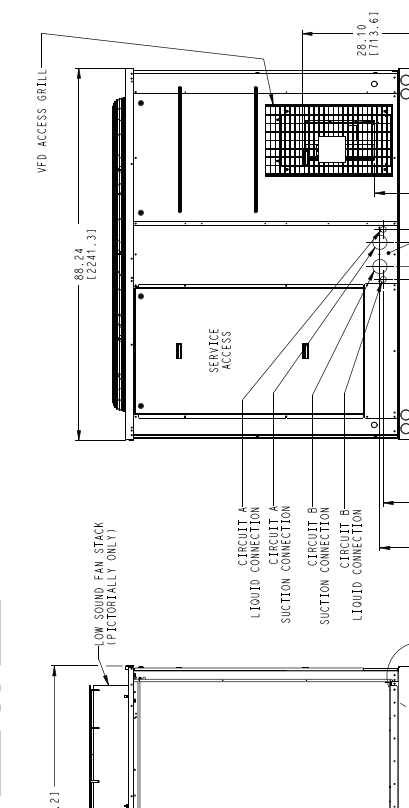
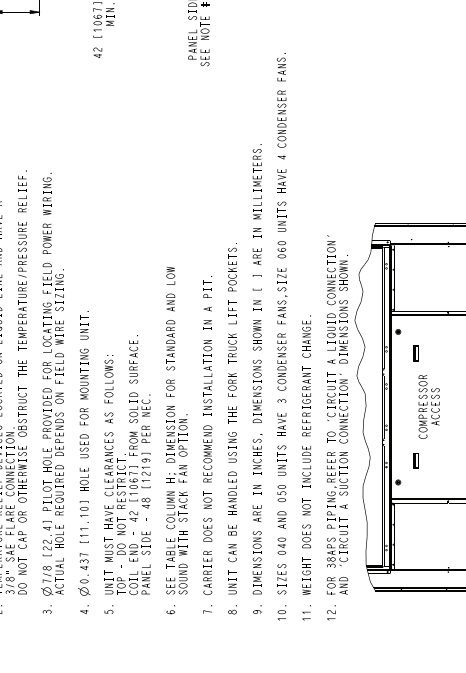
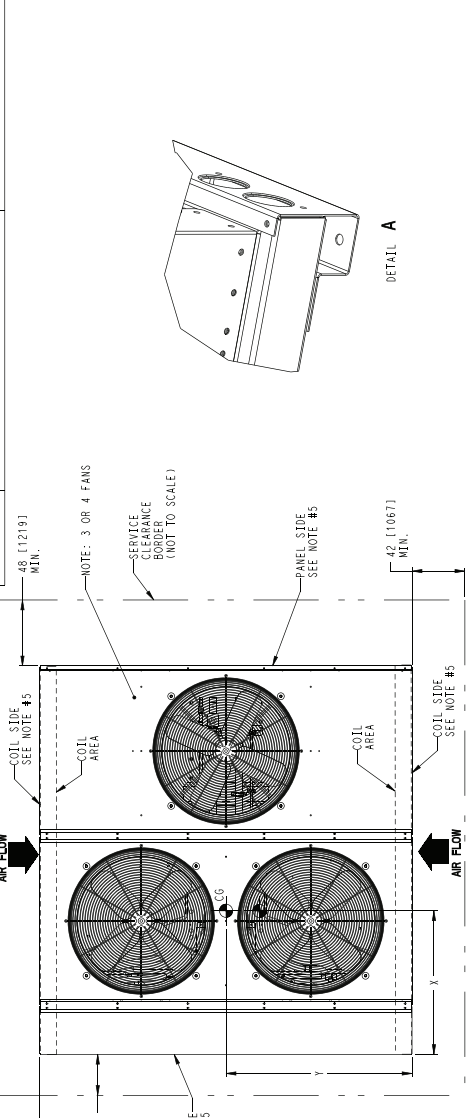

UNIT	STD. UNIT WEIGHT		CENTER OF GRAVITY		UNIT HEIGHT		SERVICE VALVE CONNECTIONS	
	LBS.	KG.	X	Y	H	SUCTION	LIQUID	
38AP040	1968	893	35.0 (889)	44.0 (1118)	2-178 (54)	7-8 (22)	2-178 (54)	7-8 (22)
38AP040	2094	950	33.7 (856)	44.1 (1120)	1-578 (141)	5/8 (16)	1-578 (141)	5/8 (16)
38AP050	1977	897	34.9 (886)	44.0 (1118)	2-178 (54)	7-8 (22)	2-178 (54)	7-8 (22)
38AP050	2120	961	33.4 (848)	44.1 (1120)	1-578 (141)	5/8 (16)	1-578 (141)	5/8 (16)
38AP060	2227	1010	34.4 (874)	44.1 (1120)	1-578 (141)	5/8 (16)	1-578 (141)	5/8 (16)

I/C CLASSIFICATION	SHEET	DATE	SUBREVISED	REV		38AP040-060 / GREENSPEED OPTION	REV
				REV #	DATE		
U.S. - ECCN:EAR99	2 OF 2	12/14/21	02/28/19			38AP55556	J

## 38AP065.070 UNITS

UNIT	CENTER OF GRAVITY		UNIT HEIGHT		SERVICE VALVE CONNECTIONS			SERVICE VALVE LOCATIONS	
	X	Y	H		SUCTION	CIRCUIT B	LIQUID	S1	S2
STANDARD	36.2 (919)	43.6 (1108)	73.0 (1854)			2-5/8 (67)	7/8 (22)	9.26 (235.2)	20.81 (528.6)
	50.9 (1293)	40.6 (1031)	73.0 (1854)		1-5/8 (41)	2-1/8 (54)	7/8 (22)	12.85 (326.4)	14.04 (356.6)
LOW SOUND	35.1 (892)	34.5 (876)	78.5 (1994)			2-5/8 (67)	7/8 (22)	9.26 (235.2)	20.81 (528.6)
	50.9 (1293)	40.6 (1031)	78.5 (1994)		1-5/8 (41)	2-1/8 (54)	7/8 (22)	12.85 (326.4)	14.04 (356.6)

- NOTES:
- BE SURE TO USE A WET RAG AND REMOVE ALL VALVE CORES BEFORE BRAZING FIELD PIPING.
  - TEMPERATURE RELIEF DEVICES LOCATED ON LIQUID LINE AND HAVE A 3/8" W/ 45° FLARE CONNECTION. DO NOT CAP OR OTHERWISE OBSTRUCT THE TEMPERATURE/PRESSURE RELIEF.
  - Ø 7/8 (22.4) PILOT HOLE PROVIDED FOR LOCATING FIELD POWER WIRING. ACTUAL HOLE REQUIRED DEPENDS ON FIELD WIRE SIZING.
  - Ø 0.524 (13.3091) HOLE USED FOR MOUNTING UNIT.
  - UNIT MUST HAVE CLEARANCES AS FOLLOWS:  
TOP - DO NOT RESTRICT.  
PANEL SIDE - 48" (1219) PER NEC.  
SIDES - 6" (152.4) FROM SOLID SURFACE FOR AIRFLOW.  
END - 8" (203.2) FROM SOLID SURFACE FOR COIL SERVICE AREA.  
SIDES - 8" (203.2) REQUIRED FOR COIL SERVICE AREA.
  - SEE TABLE COLUMN H: DIMENSION FOR STANDARD AND LOW SOUND WITH STACK FAN OPTION.
  - CARRIER DOES NOT RECOMMEND INSTALLATION IN A PIT.
  - UNIT CAN BE HANDLED USING CRANE. REFER TO SERVICE INSTALLATION INSTRUCTION.
  - DIMENSIONS ARE IN INCHES. DIMENSIONS SHOWN IN [ ] ARE IN MILLIMETERS.
  - WEIGHT DOES NOT INCLUDE REFRIGERANT CHARGE.

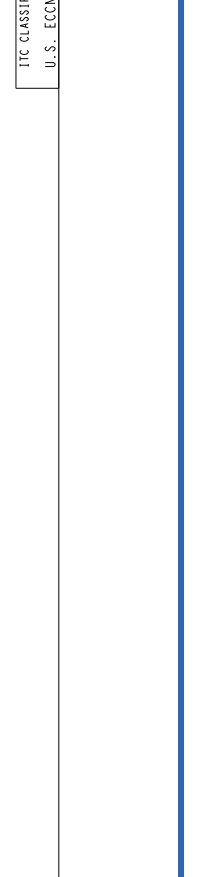
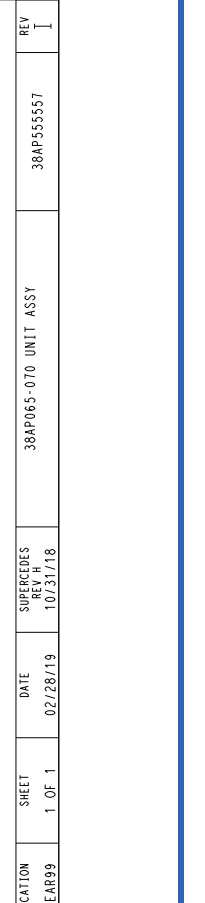
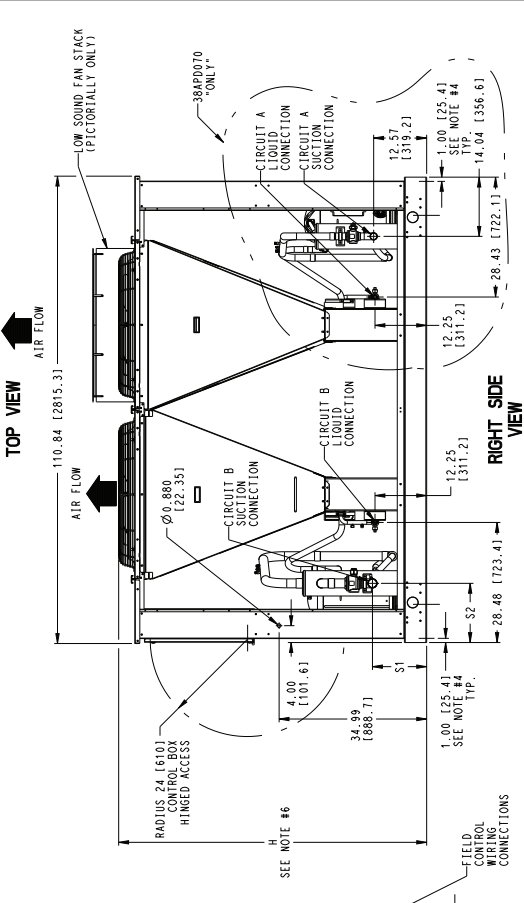
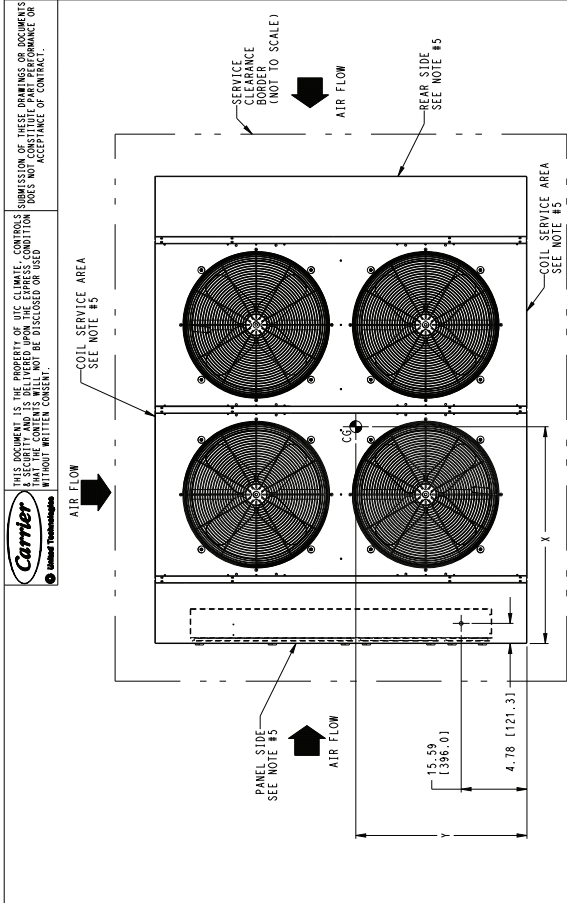

TIC CLASSIFICATION	SHEET	DATE	SUBSEQUES	REV	REV
U.S. - ECCN:EAR99	1 OF 1	02/28/19	REV H	107/31/18	38AP555557



# Dimensions (cont)



## 38AP080-100 UNITS

THIS DOCUMENT IS THE PROPERTY OF UTC CLIMATE CONTROLS. SUBMISSION OF THESE DRAWINGS OR DOCUMENTS IN ANY MANNER, OR REPRODUCTION, COPIING, OR DISTRIBUTION OF THESE DRAWINGS OR DOCUMENTS WITHOUT WRITTEN CONSENT, IS STRICTLY PROHIBITED.

**Carrier**  
 Climate Controls  
 A Carrier Company

UNIT	CENTER OF GRAVITY		UNIT HEIGHT	SERVICE VALVE CONNECTIONS		
	X	Y		SUCTION	CIRCUIT A	CIRCUIT B
STANDARD	38AP080	67.6 (1716)	40.2 (1020)	1-5/8 (41)	2-1/8 (54)	7/8 (22)
	38AP090	72.4 (1839)	43.3 (1099)	2-1/8 (54)		7/8 (22)
	38APD100	72.6 (1844)	43.3 (1099)	2-1/8 (54)		7/8 (22)
LOW SOUND	38AP080	67.6 (1716)	40.2 (1020)	1-5/8 (41)	2-1/8 (54)	7/8 (22)
	38AP090	72.4 (1839)	43.3 (1099)	2-1/8 (54)		7/8 (22)
	38APD100	72.6 (1844)	43.3 (1099)	2-1/8 (54)		7/8 (22)

NOTES: 1. BE SURE TO USE A WET RAG AND REMOVE ALL VALVE GORES BEFORE BRAZING FIELD PIPING.  
 2. TEMPERATURE RELIEF DEVICES LOCATED LIQUID LINE AND HAVE A 3/8" SAE FLARE CONNECTION. DO NOT CAP OR OTHERWISE OBSTRUCT THE TEMPERATURE/PRESSURE RELIEF.  
 3. Ø 7/8 (22.4) PILOT HOLE PROVIDED FOR LOCATING FIELD POWER WIRING. ACTUAL HOLE REQUIRED DEPENDS ON FIELD WIRE SIZING.  
 4. Ø 0.524 (13.309) HOLE USED FOR MOUNTING UNIT.  
 5. UNIT MUST HAVE CLEARANCES AS FOLLOWS:  
 TOP - DO NOT RESTRICT.  
 SIDE - 1" (25.4) PER NEC.  
 BOTTOM - 1" (25.4) PER NEC.  
 FROM SOLID SURFACE FOR AIRFLOW COLL END - 42" (1067) FROM SOLID SURFACE FOR AIRFLOW COLL END - 8" (203) REQUIRED FOR COIL SERVICE AREA.  
 6. SEE TABLE COLUMN H: DIMENSION FOR STANDARD AND LOW SOUND WITH STACK FAN OPTION.  
 7. CARRIER DOES NOT RECOMMEND INSTALLATION IN A PIT.  
 8. UNIT CAN BE HANDLED USING CRANE. REFER TO SERVICE INSTALLATION INSTRUCTION.  
 9. DIMENSIONS ARE IN INCHES. DIMENSIONS SHOWN IN ( ) ARE IN MILLIMETERS.  
 10. SIZE 080 UNITS HAVE 5 CONDENSER FANS SIZES 090 AND 100 UNITS HAVE 6 CONDENSER FANS.  
 11. WEIGHT DOES NOT INCLUDE UNIT REFRIGERANT CHARGE.

**TOP VIEW**  
 AIR FLOW  
 COIL SERVICE AREA - SEE NOTE #5  
 SERVICE CLEARANCE BORDER (NOT TO SCALE)  
 REAR SIDE - SEE NOTE #5  
 COIL SERVICE AREA - SEE NOTE #5  
 AIR FLOW  
 PANEL SIDE - SEE NOTE #5  
 4.71 (121.31)  
 15.61 (396.41)  
 X  
 151.09 (3837.61)  
 AIR FLOW  
 LOW SOUND FAN STACK (PICTORIALLY ONLY)

**RIGHT SIDE VIEW**  
 AIR FLOW  
 RADIUS 24 (610)  
 FIELD POWER ENTRY - SEE NOTE #3  
 Ø 7/8 (22.4)  
 4.00 (101.6)  
 24.89 (628.71)  
 12.85 (326.41)  
 1.00 (25.4)  
 14.04 (356.61)  
 28.48 (723.41)  
 12.25 (311.2)  
 28.45 (722.61)  
 12.85 (326.41)  
 1.00 (25.4)  
 14.04 (356.51)  
 28.45 (722.61)  
 H  
 SEE NOTE #6  
 SEE DETAIL A

**FRONT VIEW**  
 1.50 (38.1) TYP.  
 88.24 (2241.21)  
 CONTROL BOX HINGED ACCESS  
 FIELD COIL WIRING CONNECTIONS  
 1.50 (38.1) SEE NOTE #4 TYP.  
 SEE DETAIL A

**DETAIL A**

TIC CLASSIFICATION: U.S. - ECCN:EAR99  
 SHEET: 1 OF 1  
 DATE: 02/28/19  
 SUPERCEDES: 10731/18  
 38AP080-100 UNIT ASSY  
 38AP555558  
 REV: H

## 38AP115, 130 UNITS

UNIT	CENTER OF GRAVITY		UNIT HEIGHT	SERVICE VALVE CONNECTIONS				SERVICE VALVE LOCATIONS	
	X	Y		SUCTION	CIRCUIT A	CIRCUIT B	LIQUID	L1	L2
STANDARD	71.1 [1806]	44.4 [1128]	73.0 [1854]	2-1/8 [54]	2-5/8 [67]	7/8 [22]	7/8 [22]	28.48 [723]	12.25 [311]
LOW SOUND	70.9 [1801]	44.6 [1133]	78.5 [1994]	2-1/8 [54]	2-5/8 [67]	7/8 [22]	7/8 [22]	28.36 [720]	11.97 [304]

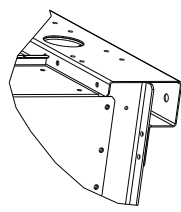
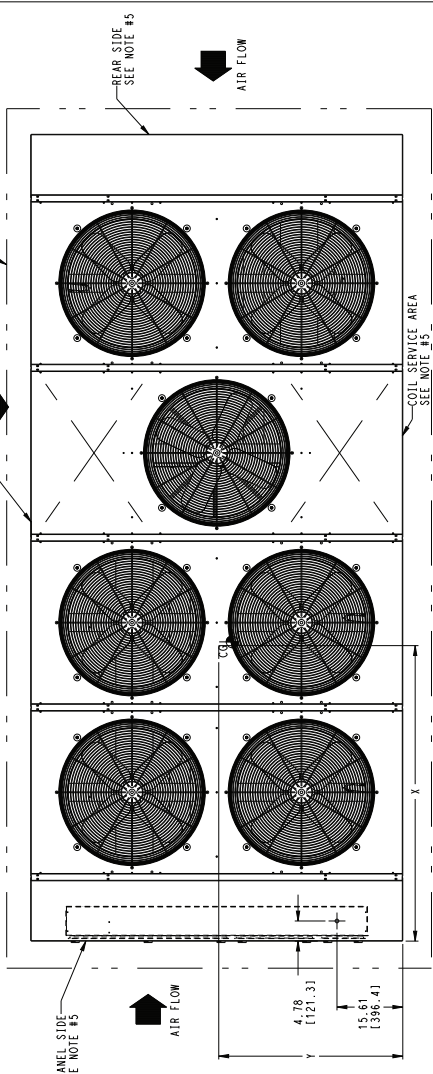

- NOTES:
1. BE SURE TO USE A WET RAG AND REMOVE ALL VALVE CORES BEFORE BRAZING FIELD PIPING.
  2. TEMPERATURE RELIEF DEVICES LOCATED ON LIQUID LINE AND HAVE A 3/8" SAE FLARE CONNECTION. DO NOT CAP OR OTHERWISE OBSTRUCT THE TEMPERATURE/PRESSURE RELIEF.
  3. Ø 7/8 [22.41] PILOT HOLE PROVIDED FOR LOCATING FIELD POWER WIRING. ACTUAL HOLE REQUIRED DEPENDS ON FIELD WIRE SIZING.
  4. Ø 0.524 [13.309] HOLE USED FOR MOUNTING UNIT.
  5. UNIT MUST HAVE CLEARANCES AS FOLLOWS:  
TOP - DO NOT RESTRICT.  
PANEL SIDE - 48 [1220] PER NEC.  
COIL END - 42 [1067] FROM SOLID SURFACE FOR AIRFLOW SIDES - 8 [203] REQUIRED FOR COIL SERVICE AREA.  
6. SEE TABLE COLUMN "H" DIMENSION FOR STANDARD AND LOW SOUND WITH STACK FAN OPTION.
  7. CARRIER DOES NOT RECOMMEND INSTALLATION IN A PIT.
  8. UNIT CAN BE HANDLED USING CRANE. REFER TO SERVICE INSTALLATION INSTRUCTION.
  9. DIMENSIONS ARE IN INCHES; DIMENSIONS SHOWN IN ( ) ARE IN MILLIMETERS.
  10. WEIGHT DOES NOT INCLUDE REFRIGERANT CHARGE.
  11. SIZE 115 UNITS HAVE 3 CONDENSER FANS. SIZE 130 UNITS HAVE 6 CONDENSER FANS.

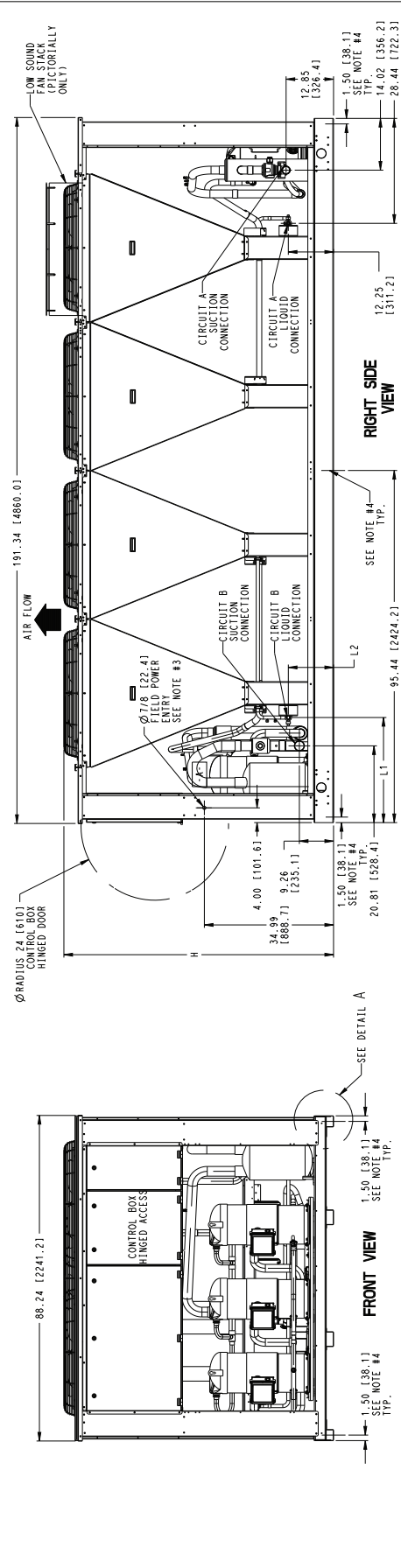

ITC CLASSIFICATION	SHEET	DATE	SUBSEQUENT REV. F.	REV
U.S. - ECCN:EAR99	1 OF 1	02/28/19	107/31/18	G

REV	DESCRIPTION	DATE
38AP555559	38AP115-130 UNIT ASSY	

## To select a 38AP stand-alone condensing unit:

Use Carrier's **Commercial Split Systems Builder** program to select a stand-alone outdoor unit from the Installation Configuration drop down menu and input the job requirements. From the list presented, select a 38AP condensing unit that is estimated to meet capacity requirements. The 38APS single-circuit unit is offered in sizes 025-065 and the 38APD dual-circuit unit is offered in sizes 025-130. After a 38AP unit is selected, the program will calculate the condensing unit performance.

## To select 38AP systems:

### For systems with one 40RU fan coil unit or 39 Series air handler

Use Carrier's **Commercial Split Systems Builder** program to select a combined 38AP outdoor unit with matched 40RU indoor unit for sizes 025-030. The **AHUBuilder**<sup>®</sup> selection program is available to select 38AP outdoor units with a matching 39 Series air handler with direct-expansion (DX) coils. The 38APS single-circuit unit is offered in sizes 025-065 and 38APD dual-circuit unit is offered in sizes 025-130. Enter the software program and input the job requirements. From the list presented, select a 38AP condensing unit that is estimated to meet capacity requirements. After selecting a 38AP unit,

check its performance with one or several DX coils. From the DX coil list presented on the screen, match the 38AP with any coil or all coils. The program calculates the combined performance of the condensing unit and each DX coil and presents the resulting system capacities and operating temperatures. Matching thermostatic expansion valves and nozzles for the DX coils are automatically selected and displayed.

### For systems with two air handlers

Use Carrier's **AHUBuilder**<sup>®</sup> selection program to select one size 025-130 38AP outdoor unit to match with two 39 Series air handlers with DX coils. For the first air handler, enter the **AHUBuilder** selection program and input the job requirements. To choose a condensing unit, select the "Specify Your Own" option. The program asks for condensing unit capacities and SDT (saturated discharge temperature) at 30°F (-1.1°C) and 50°F (10°C) SST (saturated suction temperature). The SDT must first be determined by running a standalone outdoor unit in the **Commercial Split Systems Builder** program. Enter the capacities from condenser circuit A or B and SDT for circuits A and B into the **AHUBuilder** program (remember to use the correct air temperature entering condenser column when locating the circuit capacities). For the second air handler, repeat the procedure to select the second DX coil for the condenser circuit (A or B) not used in the first selection.

# Performance data



Performance data for both MCHX and RTPF coils may be found in the Product Library of the **Commercial Split Systems Builder**.



## ROOFTOP INSTALLATION — 38AP UNITS

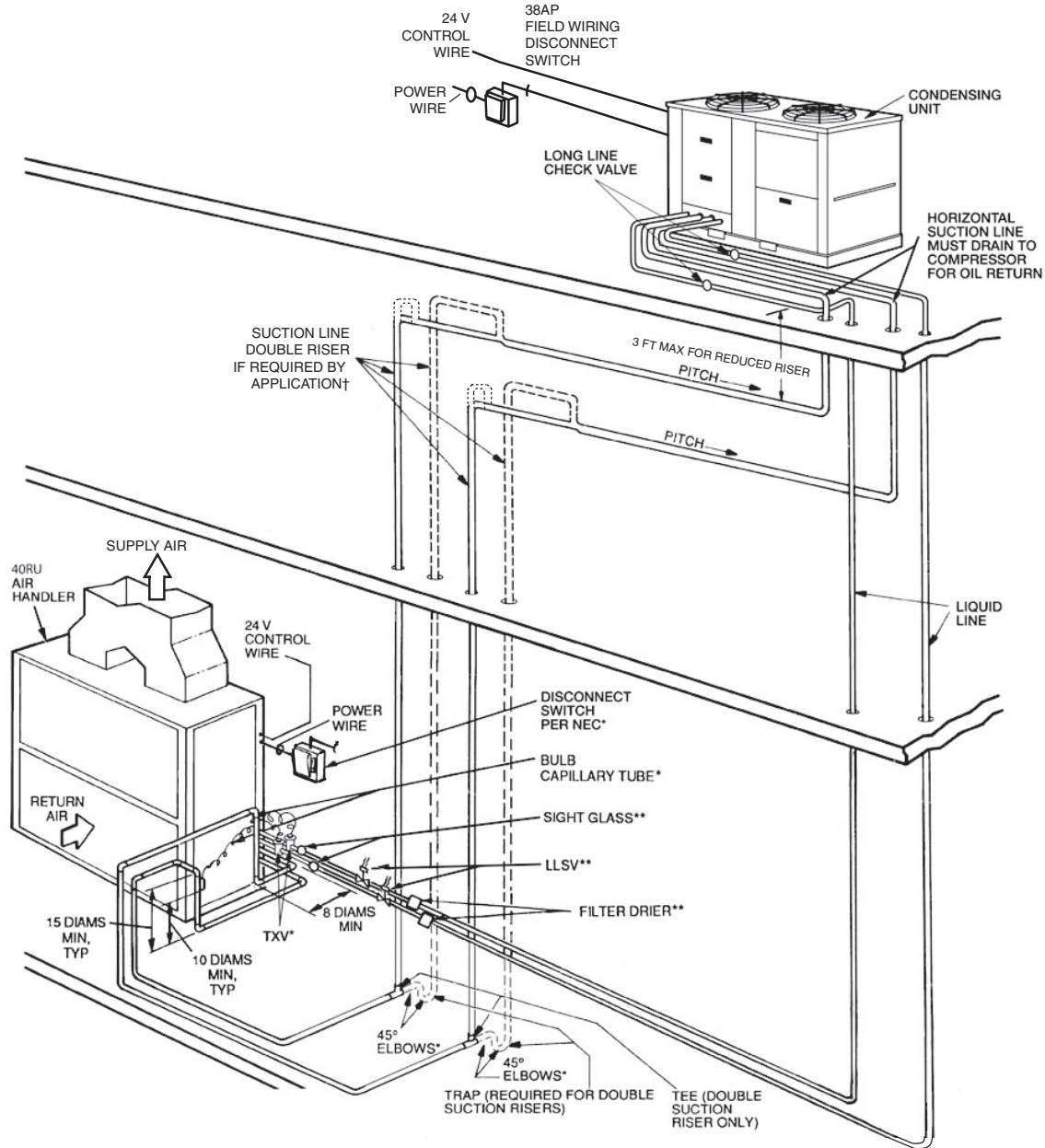

### LEGEND

- LLSV** — Liquid Line Solenoid Valve
- NEC** — National Electrical Code
- TXV** — Thermostatic Expansion Valve
- Piping
- Double Riser Piping (if required)

\* Field supplied.

† If double suction riser is required for piping system, size pipe diameter of 3 ft (0.9 m) (maximum) riser according to application data.

\*\* Field supplied. See Refrigerant Specialties Part Numbers table on page 23.

### NOTES:

1. All piping must follow standard refrigerant piping techniques. Refer to Carrier System Design Manual for details.
2. All wiring must comply with the applicable local and national codes.
3. Wiring and piping shown are general points-of-connection guides only and are not intended for, or to include all details for, a specific installation.
4. Install field-supplied disconnect switch in accordance with all local and national electrical codes.
5. Liquid line solenoid valves (solenoid drop control) are recommended on all applications to prevent refrigerant migration to the compressor. Liquid line solenoid valves are required on applications having 75 ft (23 m) or greater pipe length or if the evaporator surface area exceeds limits defined in the installation instructions.
6. Factory-supplied accumulator not shown.
7. Dual-circuit piping shown. Single-circuit piping is similar but would only have one suction line and one liquid line.
8. A field-supplied, 5 to 15% bleed port TXV is required for every application.
9. Sight glass, LLSV, and filter drier are field supplied.
10. Long line length check valves are required for liquid line installation on all linear line length applications of more than 100 ft (30.5 m). For any 025-030 size dual-circuit unit application where evaporator is located higher than the condensing unit, check valves are required for linear line length above 55 ft (16.8 m).

## GROUND LEVEL INSTALLATION — 38AP UNITS

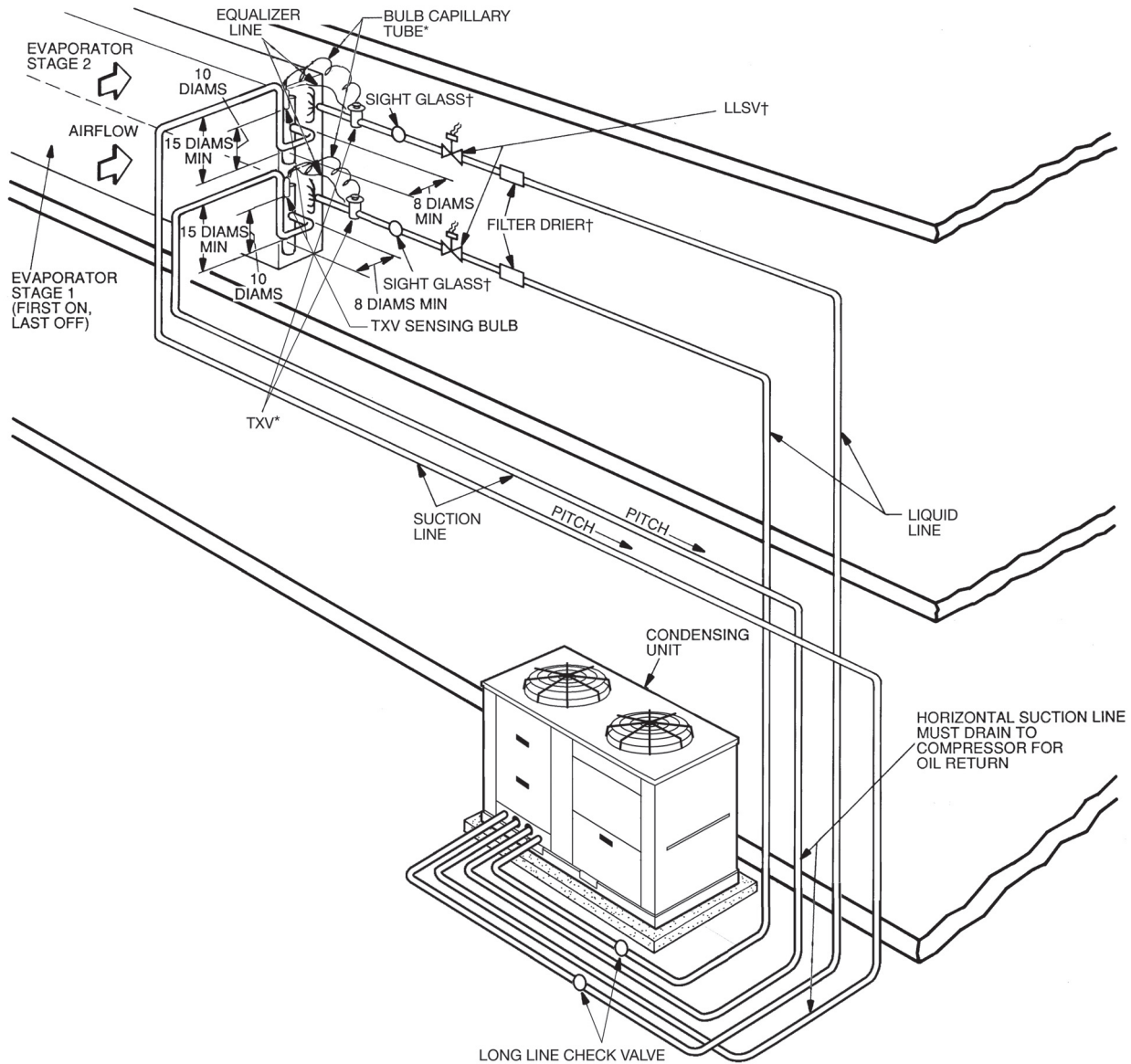

### LEGEND

- LLSV** — Liquid Line Solenoid Valve
- NEC** — National Electrical Code
- TXV** — Thermostatic Expansion Valve
- Piping

\* Field supplied.

† Field supplied. See Refrigerant Specialties Part Numbers table on page 23.

### NOTES:

1. All piping must follow standard refrigerant piping techniques. Refer to Carrier System Design Manual for details.
2. All wiring must comply with the applicable local and national codes.
3. Wiring and piping shown are general points-of-connection guides only and are not intended for, or to include all details for, a specific installation.
4. Install field-supplied disconnect switch in accordance with all local and national electrical codes.
5. Liquid line solenoid valves (solenoid drop control) are recommended on all applications to prevent refrigerant migration to the compressor. Liquid line solenoid valves are required on applications having 75 ft (23 m) or greater pipe length or if the evaporator surface area exceeds limits defined in the installation instructions.
6. Factory-supplied accumulator not shown.
7. Dual-circuit piping shown. Single-circuit piping is similar but would only have one suction line and one liquid line.
8. A field-supplied, 5 to 15% bleed port TXV is required for every application.
9. Sight glass, LLSV, and filter drier are field supplied.
10. Long line length check valves are required for liquid line installation on all linear line length applications of more than 100 ft (30.5 m). For any 025-030 size dual-circuit unit application where evaporator is located higher than the condensing unit, check valves are required for linear line length above 55 ft (16.8 m).

# Typical piping and wiring (cont)



## REFRIGERANT SPECIALTIES PART NUMBERS

38APS UNIT SIZE	CIRCUIT A						
	Tons	LL Size (in.)	LLSV	LLSV Coil 24-v, 50/60 Hz	Sight Glass	Filter Drier	Filter Drier Core
025	24.0	5/8 7/8	EF680028	EF680032	KM680005	KH680002	KH680008
			EF680029	EF680032	KM680006	KH680003	KH680008
027	26.7	5/8 7/8	EF680028	EF680032	KM680005	KH680002	KH680008
			EF680029	EF680032	KM680006	KH680003	KH680008
030	31.1	5/8 7/8 1-1/8	EF680028	EF680032	KM680005	KH680002	KH680008
			EF680029	EF680032	KM680006	KH680003	KH680008
			EF680030	EF680032	KM680007	KH680004	KH680008
040	39.8	5/8 7/8 1-1/8	EF680028	EF680032	KM680005	KH680003*	KH680008
			EF680029	EF680032	KM680006	KH680003	KH680008
			EF680030	EF680032	KM680007	KH680004	KH680008
050	48.1	7/8 1-1/8 7/8	EF680029	EF680032	KM680006	KH680003	KH680008
			EF680030	EF680032	KM680007	KH680004	KH680008
065	59.6	1-1/8 1-3/8	EF680029	EF680032	KM680006	KH680003	KH680008
			EF680030	EF680032	KM680007	KH680004	KH680008
			EF680038	EF680032	KM680007*	KH680012	KH680008

38APD UNIT SIZE	CIRCUIT A							CIRCUIT B						
	Tons	LL Size (in.)	LLSV	LLSV Coil 24-v, 50/60 Hz	Sight Glass	Filter Drier	Filter Drier Core	Tons	LL Size (in.)	LLSV	LLSV Coil 24-v, 50/60 Hz	Sight Glass	Filter Drier	Filter Drier Core
025	12.0	1/2 5/8	EF680031	EF680032	KM680004	KH680001	—	12.0	1/2 5/8	EF680031	EF680032	KM680004	KH680001	—
			EF680028	EF680032	KM680005	KH680002	KH680008			EF680028	EF680032	KM680005	KH680002	KH680008
027	13.3	1/2 5/8	EF680031	EF680032	KM680004	KH680001	—	13.3	1/2 5/8	EF680031	EF680032	KM680004	KH680001	—
			EF680028	EF680032	KM680005	KH680002	KH680008			EF680028	EF680032	KM680005	KH680002	KH680008
030	15.6	1/2 5/8 7/8	EF680031	EF680032	KM680004	KH680001	—	15.6	1/2 5/8 7/8	EF680031	EF680032	KM680004	KH680001	—
			EF680028	EF680032	KM680005	KH680002	KH680008			EF680028	EF680032	KM680005	KH680002	KH680008
			EF680029	EF680032	KM680006	KH680003	KH680008			EF680029	EF680032	KM680006	KH680003	KH680008
040	21.0	5/8 7/8	—	—	—	—	—	18.2	1/2 5/8 7/8	EF680028	EF680032	KM680004	KH680001	—
			EF680028	EF680032	KM680005	KH680002	KH680008			EF680029	EF680032	KM680005	KH680002	KH680008
			EF680029	EF680032	KM680006	KH680003	KH680008			EF680028	EF680032	KM680006	KH680003	KH680008
050	23.8	5/8 7/8	EF680028	EF680032	KM680005	KH680002	KH680008	26.3	5/8 7/8	EF680028	EF680032	KM680005	KH680002	KH680008
			EF680029	EF680032	KM680006	KH680003	KH680008			EF680029	EF680032	KM680006	KH680003	KH680008
060	26.8	5/8 7/8	EF680028	EF680032	KM680005	KH680002	KH680008	31.5	5/8 7/8	EF680028	EF680032	KM680005	KH680002	KH680008
			EF680029	EF680032	KM680006	KH680003	KH680008			EF680029	EF680032	KM680006	KH680003	KH680008
070	31.8	5/8 7/8 1-1/8	EF680028	EF680032	KM680005	KH680002	KH680008	35.5	5/8 7/8 1-1/8	EF680028	EF680032	KM680005	KH680002	KH680008
			EF680029	EF680032	KM680006	KH680003	KH680008			EF680029	EF680032	KM680006	KH680003	KH680008
			EF680030	EF680032	KM680007	KH680004	KH680008			EF680030	EF680032	KM680007	KH680004	KH680008
080	31.3	5/8 7/8 1-1/8	EF680028	EF680032	KM680005	KH680002	KH680008	46.7	5/8 7/8 1-1/8	EF680028	EF680032	KM680005	KH680003*	KH680008
			EF680029	EF680032	KM680006	KH680003	KH680008			EF680029	EF680032	KM680006	KH680003	KH680008
			EF680030	EF680032	KM680007	KH680004	KH680008			EF680030	EF680032	KM680007	KH680004	KH680008
090	40.3	5/8 7/8 1-1/8	EF680028	EF680032	KM680005	KH680003*	KH680008	47.1	7/8 1-1/8	EF680029	EF680032	KM680006	KH680003	KH680008
			EF680029	EF680032	KM680006	KH680003	KH680008			EF680030	EF680032	KM680007	KH680004	KH680008
100	48.0	7/8 1-1/8	EF680029	EF680032	KM680006	KH680003	KH680008	48.0	7/8 1-1/8	EF680029	EF680032	KM680006	KH680003	KH680008
			EF680030	EF680032	KM680007	KH680004	KH680008			EF680030	EF680032	KM680007	KH680004	KH680008
115	48.0	7/8 1-1/8	EF680029	EF680032	KM680006	KH680003	KH680008	62.4	7/8 1-1/8	EF680029	EF680032	KM680006	KH680003	KH680008
			EF680030	EF680032	KM680007	KH680004	KH680008			EF680030	EF680032	KM680007	KH680004	KH680008
130	48.0	7/8 1-1/8	EF680029	EF680032	KM680006	KH680003	KH680008	77.1	7/8 1-1/8 1-3/8	EF680029	EF680032	KM680006	KH680003	KH680008
			EF680030	EF680032	KM680007	KH680004	KH680008			EF680030	EF680032	KM680007	KH680004	KH680008
			—	—	—	—	—			EF680038	EF680032	KM680007*	KH680012	KH680008

**LEGEND**

LL — Liquid Line  
 LLSV — Liquid Line Solenoid Valve

\*Bushing required to fit 5/8 in. line.

**NOTES:**

- Filter driers have been sized based upon 1 to 2 psig (250 to 500 Pa) pressure drop clean in accordance with AHRI Standard 710. Filter drier KH680001 is a hermetically sealed beaded drier that does not require a replaceable core. All other filter driers listed require the filter core KH680008, which is replaceable and sold separately (not included).
- Thermostatic expansion valve (TXV) is provided with all 40RU fan coil units. Contact your Carrier representative for appropriate TXV size.

- All pipe sizes are OD inches. Equivalent sizes in millimeters follow:

in.	mm
1/2	12.7
5/8	15.9
7/8	22.2
1-1/8	28.6
1-3/8	34.9

- Liquid line solenoid valves (solenoid drop control) are recommended on all applications to prevent refrigerant migration to the compressor. Liquid line solenoid valves are required on applications having 75 ft (23 m) or greater pipe length or if the evaporator surface area exceeds limits defined in the installation instructions.

## 38APS ELECTRICAL DATA — SINGLE POINT STANDARD FAN

38APS UNIT SIZE	V-Ph-Hz	SUPPLY VOLTAGE		COMPRESSOR			CONDENSER FAN		MCA	MOCP	REC FUSE	ICF
		Min	Max	Qty	RLA	LRA	Total Qty	FLA				
025	208/230-3-60	187	254		48.1	245		6.6	121.4	150	150	306.3
	380-3-60	342	418		23.7	145		3.9	61.1	80	70	176.5
	460-3-60	414	506	2	18.6	125	2	3.3	48.5	60	60	150.2
	575-3-60	518	632		14.7	100		2.6	38.3	50	45	119.9
	380/415-3-50	342	440		18.6	118		3.3	48.5	60	60	143.2
027	208/230-3-60	187	254		51.3	300		6.6	128.6	175	150	364.5
	380-3-60	342	418		26.9	139		3.9	68.3	90	80	173.7
	460-3-60	414	506	2	23.1	150	2	3.3	58.6	80	70	179.7
	575-3-60	518	632		19.9	109		2.6	50.0	60	60	134.1
	380/415-3-50	342	440		23.1	140		3.3	58.6	80	70	169.7
030	208/230-3-60	187	254		55.8	340		6.6	138.8	175	175	409.0
	380-3-60	342	418		34.0	196		3.9	84.3	110	100	237.8
	460-3-60	414	506	2	26.9	179	2	3.3	67.1	90	80	212.5
	575-3-60	518	632		23.7	132		2.6	58.5	80	70	160.9
	380/415-3-50	342	440		26.9	174		3.3	67.1	90	80	207.5
040	208/230-3-60	187	254		51.3	300		6.6	186.5	225	200	422.4
	380-3-60	342	418		26.9	139		3.9	99.1	125	110	204.5
	460-3-60	414	506	3	23.1	150	3	3.3	85.0	100	100	206.1
	575-3-60	518	632		19.9	109		2.6	72.5	90	80	156.6
	380/415-3-50	342	440		23.1	140		3.3	85.0	100	100	196.1
050	208/230-3-60	187	254		55.8	340		6.6	201.2	250	225	471.4
	380-3-60	342	418		34.0	196		3.9	122.2	150	150	275.7
	460-3-60	414	506	3	26.9	179	3	3.3	97.3	110	110	242.7
	575-3-60	518	632		23.7	132		2.6	84.8	100	100	187.2
	380/415-3-50	342	440		26.9	174		3.3	97.3	110	110	237.7
065	208/230-3-60	187	254		72.4	538		6.6	261.7	300	300	709.2
	380-3-60	342	418		35.3	290		3.9	130.3	150	150	376.2
	460-3-60	414	506	3	30.8	229	4	3.3	113.3	125	125	303.8
	575-3-60	518	632		25.0	180		2.6	91.7	110	100	240.4
	380/415-3-50	342	440		30.8	229		3.3	113.3	125	125	303.8

### LEGEND

- FLA** — Full Load Amps
- ICF** — Maximum Instantaneous Current Flow
- LRA** — Locked Rotor Amps
- MCA** — Minimum Circuit Amps
- MOCP** — Maximum Overcurrent Protection
- RLA** — Rated Load Amps

### NOTES:

1. Units are suitable for use on electrical systems where voltage supplied to the unit terminals is not below or above the listed minimum and maximum limits. Maximum allowable phase imbalance is: voltage 2%; amps 10%.
2. All units or modules have single point primary power connection. Main power must be supplied from a field-supplied disconnect.
3. For MCA that is less than or equal to 380 amps, 3 conductors are required.
4. For MCA between 381 and 760 amps, 6 conductors are required.
5. Calculation of conductors required is based on 75°C copper wire.

6. Wiring for main field supply must be rated 75°C. Use copper conductors only.

- a. Incoming wire size range for terminal block with MCA up to 175 amps is 14 AWG (American Wire Gage) to 2/0.
- b. Incoming wire size range for terminal block with MCA from 175.1 amps to 420 amps is 2 AWG to 600 kcmil.
- c. Incoming wire size range for non-fused disconnect with MCA up to 100 amps is 14 AWG to 1/0.
- d. Incoming wire size range for non-fused disconnect with MCA from 100.1 amps to 200 amps is 6 AWG to 350 kcmil.
- e. Incoming wire size range for non-fused disconnect with MCA from 200.1 amps to 450 amps is 3/0 to 500 kcmil.



## 38APS ELECTRICAL DATA — SINGLE POINT LOW SOUND FAN

38APS UNIT SIZE	V-Ph-Hz	SUPPLY VOLTAGE		COMPRESSOR			CONDENSER FAN		MCA	MOCP	REC FUSE	ICF
		Min	Max	Qty	RLA	LRA	Total Qty	FLA				
025	208/230-3-60	187	254		48.1	245		6.0	120.2	150	150	305.1
	380-3-60	342	418		23.7	145		3.9	61.1	80	70	176.5
	460-3-60	414	506	2	18.6	125	2	2.9	47.7	60	60	149.4
	575-3-60	518	632		14.7	100		2.4	37.9	50	45	119.5
	380/415-3-50	342	440		18.6	118		2.9	47.7	60	60	142.4
027	208/230-3-60	187	254		51.3	300		6.0	127.4	175	150	363.3
	380-3-60	342	418		26.9	139		3.9	68.3	90	80	173.7
	460-3-60	414	506	2	23.1	150	2	2.9	57.8	80	70	178.9
	575-3-60	518	632		19.9	109		2.4	49.6	60	60	133.7
	380/415-3-50	342	440		23.1	140		2.9	57.8	80	70	168.9
030	208/230-3-60	187	254		55.8	340		6.0	137.6	175	175	407.8
	380-3-60	342	418		34.0	196		3.9	84.3	110	100	237.8
	460-3-60	414	506	2	26.9	179	2	2.9	66.3	90	80	211.7
	575-3-60	518	632		23.7	132		2.4	58.1	80	70	160.5
	380/415-3-50	342	440		26.9	174		2.9	66.3	90	80	206.7
040	208/230-3-60	187	254		51.3	300		6.0	184.7	225	200	420.6
	380-3-60	342	418		26.9	139		3.9	99.1	125	110	204.5
	460-3-60	414	506	3	23.1	150	3	2.9	83.8	100	100	204.9
	575-3-60	518	632		19.9	109		2.4	71.9	90	80	156.0
	380/415-3-50	342	440		23.1	140		2.9	83.8	100	100	194.9
050	208/230-3-60	187	254		55.8	340		6.0	199.4	250	225	469.6
	380-3-60	342	418		34.0	196		3.9	122.2	150	150	275.7
	460-3-60	414	506	3	26.9	179	3	2.9	96.1	110	110	241.5
	575-3-60	518	632		23.7	132		2.4	84.2	100	100	186.6
	380/415-3-50	342	440		26.9	174		2.9	96.1	110	110	236.5
065	208/230-3-60	187	254		72.4	538		6.0	259.3	300	300	706.8
	380-3-60	342	418		35.3	290		3.9	130.3	150	150	376.2
	460-3-60	414	506	3	30.8	229	4	2.9	111.7	125	125	302.2
	575-3-60	518	632		25.0	180		2.4	90.9	110	100	239.6
	380/415-3-50	342	440		30.8	229		2.9	111.7	125	125	302.2

### LEGEND

- FLA** — Full Load Amps
- ICF** — Maximum Instantaneous Current Flow
- LRA** — Locked Rotor Amps
- MCA** — Minimum Circuit Amps
- MOCP** — Maximum Overcurrent Protection
- RLA** — Rated Load Amps

### NOTES:

1. Units are suitable for use on electrical systems where voltage supplied to the unit terminals is not below or above the listed minimum and maximum limits. Maximum allowable phase imbalance is: voltage 2%; amps 10%.
2. All units or modules have single point primary power connection. Main power must be supplied from a field-supplied disconnect.
3. For MCA that is less than or equal to 380 amps, 3 conductors are required.
4. For MCA between 381 and 760 amps, 6 conductors are required.
5. Calculation of conductors required is based on 75°C copper wire.

6. Wiring for main field supply must be rated 75°C. Use copper conductors only.

- a. Incoming wire size range for terminal block with MCA up to 175 amps is 14 AWG (American Wire Gage) to 2/0.
- b. Incoming wire size range for terminal block with MCA from 175.1 amps to 420 amps is 2 AWG to 600 kcmil.
- c. Incoming wire size range for non-fused disconnect with MCA up to 100 amps is 14 AWG to 1/0.
- d. Incoming wire size range for non-fused disconnect with MCA from 100.1 amps to 200 amps is 6 AWG to 350 kcmil.
- e. Incoming wire size range for non-fused disconnect with MCA from 200.1 amps to 450 amps is 3/0 to 500 kcmil.





## 38APD ELECTRICAL DATA — SINGLE POINT STANDARD FAN

38APD UNIT SIZE	V-Ph-Hz	SUPPLY VOLTAGE		COMPRESSOR						CONDENSER FAN		MCA	MOCP	REC FUSE	ICF
				Circuit A			Circuit B			Total Qty	FLA				
		Min	Max	Qty	RLA	LRA	Qty	RLA	LRA						
025	208/230-3-60	187	254		48.1	245		48.1	245		6.6	121.4	150	150	306.3
	380-3-60	342	418		23.7	145		23.7	145		3.9	61.1	80	70	176.5
	460-3-60	414	506	1	18.6	125	1	18.6	125	2	3.3	48.5	60	60	150.2
	575-3-60	518	632		14.7	100		14.7	100		2.6	38.3	50	45	119.9
	380/415-3-50	342	440		18.6	118		18.6	118		3.3	48.5	60	60	143.2
027	208/230-3-60	187	254		51.3	300		51.3	300		6.6	128.6	175	150	364.5
	380-3-60	342	418		26.9	139		26.9	139		3.9	68.3	90	80	173.7
	460-3-60	414	506	1	23.1	150	1	23.1	150	2	3.3	58.6	80	70	179.7
	575-3-60	518	632		19.9	109		19.9	109		2.6	50.0	60	60	134.1
	380/415-3-50	342	440		23.1	140		23.1	140		3.3	58.6	80	70	169.7
030	208/230-3-60	187	254		55.8	340		55.8	340		6.6	138.8	175	175	409.0
	380-3-60	342	418		34.0	196		34.0	196		3.9	84.3	110	100	237.8
	460-3-60	414	506	1	26.9	179	1	26.9	179	2	3.3	67.1	90	80	212.5
	575-3-60	518	632		23.7	132		23.7	132		2.6	58.5	80	70	160.9
	380/415-3-50	342	440		26.9	174		26.9	174		3.3	67.1	90	80	207.5
040	208/230-3-60	187	254		35.8	239		33.4	225		6.6	167.2	200	175	361.4
	380-3-60	342	418		23.7	145		19.2	140		3.9	103.5	125	110	218.9
	460-3-60	414	506	2	17.9	125	2	16.7	114	3	3.3	83.6	100	90	186.2
	575-3-60	518	632		14.3	80		13.4	80		2.6	66.7	80	70	128.8
	380/415-3-50	342	440		17.9	118		16.7	111		3.3	83.6	100	90	179.2
050	208/230-3-60	187	254		48.1	245		51.3	300		6.6	231.4	250	250	467.3
	380-3-60	342	418		23.7	145		26.9	139		3.9	119.6	125	125	225.0
	460-3-60	414	506	2	18.6	125	2	23.1	150	3	3.3	99.1	110	110	220.2
	575-3-60	518	632		14.7	100		19.9	109		2.6	82.0	100	90	166.1
	380/415-3-50	342	440		18.6	118		23.1	140		3.3	99.1	110	110	210.2
060	208/230-3-60	187	254		51.3	300		55.8	340		6.6	254.6	300	300	524.8
	380-3-60	342	418		26.9	139		34.0	196		3.9	145.9	175	175	299.4
	460-3-60	414	506	2	23.1	150	2	26.9	179	4	3.3	119.9	125	125	265.3
	575-3-60	518	632		19.9	109		23.7	132		2.6	103.5	125	110	205.9
	380/415-3-50	342	440		23.1	140		26.9	174		3.3	119.9	125	125	260.3
070	208/230-3-60	187	254		55.8	340		48.1	245		6.6	296.3	350	350	566.5
	380-3-60	342	418		34.0	196		23.7	145		3.9	163.2	175	175	316.7
	460-3-60	414	506	2	26.9	179	3	18.6	125	4	3.3	129.5	150	150	274.9
	575-3-60	518	632		23.7	132		14.7	100		2.6	107.8	125	125	210.2
	380/415-3-50	342	440		26.9	174		18.6	118		3.3	129.5	150	150	269.9
080	208/230-3-60	187	254		55.8	340		55.8	340		6.6	326.0	350	350	596.2
	380-3-60	342	418		34.0	196		34.0	196		3.9	198.0	225	225	351.5
	460-3-60	414	506	2	26.9	179	3	26.9	179	5	3.3	157.7	175	175	303.1
	575-3-60	518	632		23.7	132		23.7	132		2.6	137.4	150	150	239.8
	380/415-3-50	342	440		26.9	174		26.9	174		3.3	157.7	175	175	298.1
090	208/230-3-60	187	254		51.3	300		55.8	340		6.6	374.9	400	400	645.1
	380-3-60	342	418		26.9	139		34.0	196		3.9	214.6	225	225	368.1
	460-3-60	414	506	3	23.1	150	3	26.9	179	6	3.3	176.5	200	200	321.9
	575-3-60	518	632		19.9	109		23.7	132		2.6	152.3	175	150	254.7
	380/415-3-50	342	440		23.1	140		26.9	174		3.3	176.5	200	200	311.9
100	208/230-3-60	187	254		55.8	340		55.8	340		6.6	388.4	400	400	658.6
	380-3-60	342	418		34.0	196		34.0	196		3.9	235.9	250	250	389.4
	460-3-60	414	506	3	26.9	179	3	26.9	179	6	3.3	187.9	200	200	333.3
	575-3-60	518	632		23.7	132		23.7	132		2.6	163.7	175	175	266.1
	380/415-3-50	342	440		26.9	174		26.9	174		3.3	187.9	200	200	328.3
115	208/230-3-60	187	254		55.8	340		72.4	538		6.6	448.9	500	500	896.4
	380-3-60	342	418		34.0	196		35.3	290		3.9	244.0	250	250	489.9
	460-3-60	414	506	3	26.9	179	3	30.8	229	7	3.3	203.9	225	225	394.4
	575-3-60	518	632		23.7	132		25.0	180		2.6	170.6	175	175	319.3
	380/415-3-50	342	440		26.9	174		30.8	229		3.3	203.9	225	225	394.4

# Electrical data (cont)



## 38APD ELECTRICAL DATA — SINGLE POINT STANDARD FAN (cont)

38APD UNIT SIZE	V-Ph-Hz	SUPPLY VOLTAGE		COMPRESSOR						CONDENSER FAN		MCA	MOCP	REC FUSE	ICF
				Circuit A			Circuit B			Total Qty	FLA				
		Min	Max	Qty	RLA	LRA	Qty	RLA	LRA						
130	208/230-3-60	187	254		55.8	340		85.3	605		6.6	497.4	500	500	995.8
	380-3-60	342	418		34.0	196		51.9	380		3.9	301.9	350	300	617.0
	460-3-60	414	506	3	26.9	179	3	37.8	320	8	3.3	230.0	250	250	502.7
	575-3-60	518	632		23.7	132		34.6	250		2.6	204.4	225	225	411.1
	380/415-3-50	342	440		26.9	174		37.8	320		3.3	230.0	250	250	502.7

### LEGEND

- FLA** — Full Load Amps
- ICF** — Maximum Instantaneous Current Flow
- LRA** — Locked Rotor Amps
- MCA** — Minimum Circuit Amps
- MOCP** — Maximum Overcurrent Protection
- RLA** — Rated Load Amps

### NOTES:

1. Units are suitable for use on electrical systems where voltage supplied to the unit terminals is not below or above the listed minimum and maximum limits. Maximum allowable phase imbalance is: voltage 2%; amps 10%.
2. All units or modules have single point primary power connection. Main power must be supplied from a field-supplied disconnect.
3. For MCA that is less than or equal to 380 amps, 3 conductors are required.
4. For MCA between 381 and 760 amps, 6 conductors are required.
5. Calculation of conductors required is based on 75°C copper wire.
6. Wiring for main field supply must be rated 75°C. Use copper conductors only.
  - a. Incoming wire size range for terminal block with MCA up to 175 amps is 14 AWG (American Wire Gage) to 2/0.
  - b. Incoming wire size range for terminal block with MCA from 175.1 amps to 420 amps is 2 AWG to 600 kcmil.
  - c. Incoming wire size range for non-fused disconnect with MCA up to 100 amps is 14 AWG to 1/0.
  - d. Incoming wire size range for non-fused disconnect with MCA from 100.1 amps to 200 amps is 6 AWG to 350 kcmil.
  - e. Incoming wire size range for non-fused disconnect with MCA from 200.1 amps to 450 amps is 3/0 to 500 kcmil.



## 38APD ELECTRICAL DATA — SINGLE POINT LOW SOUND FAN

38APD UNIT SIZE	V-Ph-Hz	SUPPLY VOLTAGE		COMPRESSOR						CONDENSER FAN		MCA	MOCP	REC FUSE	ICF
				Circuit A			Circuit B			Total Qty	FLA				
		Min	Max	Qty	RLA	LRA	Qty	RLA	LRA						
025	208/230-3-60	187	254		48.1	245		48.1	245		6.0	120.2	150	150	305.1
	380-3-60	342	418		23.7	145		23.7	145		3.9	61.1	80	70	176.5
	460-3-60	414	506	1	18.6	125	1	18.6	125	2	2.9	47.7	60	60	149.4
	575-3-60	518	632		14.7	100		14.7	100		2.4	37.9	50	45	119.5
	380/415-3-50	342	440		18.6	118		18.6	118		2.9	47.7	60	60	142.4
027	208/230-3-60	187	254		51.3	300		51.3	300		6.0	127.4	175	150	363.3
	380-3-60	342	418		26.9	139		26.9	139		3.9	68.3	90	80	173.7
	460-3-60	414	506	1	23.1	150	1	23.1	150	2	2.9	57.8	80	70	178.9
	575-3-60	518	632		19.9	109		19.9	109		2.4	49.6	60	60	133.7
	380/415-3-50	342	440		23.1	140		23.1	140		2.9	57.8	80	70	168.9
030	208/230-3-60	187	254		55.8	340		55.8	340		6.0	137.6	175	175	407.8
	380-3-60	342	418		34.0	196		34.0	196		3.9	84.3	110	100	237.8
	460-3-60	414	506	1	26.9	179	1	26.9	179	2	2.9	66.3	90	80	211.7
	575-3-60	518	632		23.7	132		23.7	132		2.4	58.1	80	70	160.5
	380/415-3-50	342	440		26.9	174		26.9	174		2.9	66.3	90	80	206.7
040	208/230-3-60	187	254		35.8	239		33.4	225		6.0	165.4	200	175	359.6
	380-3-60	342	418		23.7	145		19.2	140		3.9	103.5	125	110	218.9
	460-3-60	414	506	2	17.9	125	2	16.7	114	3	2.9	82.4	100	90	185.0
	575-3-60	518	632		14.3	80		13.4	80		2.4	66.1	80	70	128.2
	380/415-3-50	342	440		17.9	118		16.7	111		2.9	82.4	100	90	178.0
050	208/230-3-60	187	254		48.1	245		51.3	300		6.0	229.6	250	250	465.5
	380-3-60	342	418		23.7	145		26.9	139		3.9	119.6	125	125	225.0
	460-3-60	414	506	2	18.6	125	2	23.1	150	3	2.9	97.9	110	110	219.0
	575-3-60	518	632		14.7	100		19.9	109		2.4	81.4	100	90	165.5
	380/415-3-50	342	440		18.6	118		23.1	140		2.9	97.9	110	110	212.0
060	208/230-3-60	187	254		51.3	300		55.8	340		6.0	252.2	300	300	522.4
	380-3-60	342	418		26.9	139		34.0	196		3.9	145.9	175	175	299.4
	460-3-60	414	506	2	23.1	150	2	26.9	179	4	2.9	118.3	125	125	263.7
	575-3-60	518	632		19.9	109		23.7	132		2.4	102.7	125	110	205.1
	380/415-3-50	342	440		23.1	140		26.9	174		2.9	118.3	125	125	253.7
070	208/230-3-60	187	254		55.8	340		48.1	245		6.0	293.9	350	300	564.1
	380-3-60	342	418		34.0	196		23.7	145		3.9	163.2	175	175	316.7
	460-3-60	414	506	2	26.9	179	3	18.6	125	4	2.9	127.9	150	150	273.3
	575-3-60	518	632		23.7	132		14.7	100		2.4	107.0	125	125	209.4
	380/415-3-50	342	440		26.9	174		18.6	118		2.9	127.9	150	150	268.3
080	208/230-3-60	187	254		55.8	340		55.8	340		6.0	323.0	350	350	587.2
	380-3-60	342	418		34.0	196		34.0	196		3.9	198.0	225	225	347.6
	460-3-60	414	506	2	26.9	179	3	26.9	179	5	2.9	155.7	175	175	298.2
	575-3-60	518	632		23.7	132		23.7	132		2.4	136.4	150	150	236.4
	380/415-3-50	342	440		26.9	174		26.9	174		2.9	155.7	175	175	293.2
090	208/230-3-60	187	254		51.3	300		55.8	340		6.0	371.3	400	400	641.5
	380-3-60	342	418		26.9	139		34.0	196		3.9	214.6	225	225	368.1
	460-3-60	414	506	3	23.1	150	3	26.9	179	6	2.9	174.1	200	200	319.5
	575-3-60	518	632		19.9	109		23.7	132		2.4	151.1	175	150	253.5
	380/415-3-50	342	440		23.1	140		26.9	174		2.9	174.1	200	200	309.5
100	208/230-3-60	187	254		55.8	340		55.8	340		6.0	384.8	400	400	655.0
	380-3-60	342	418		34.0	196		34.0	196		3.9	235.9	250	250	389.4
	460-3-60	414	506	3	26.9	179	3	26.9	179	6	2.9	185.5	200	200	330.9
	575-3-60	518	632		23.7	132		23.7	132		2.4	162.5	175	175	264.9
	380/415-3-50	342	440		26.9	174		26.9	174		2.9	185.5	200	200	325.9
115	208/230-3-60	187	254		55.8	340		72.4	538		6.0	444.7	500	500	892.2
	380-3-60	342	418		34.0	196		35.3	290		3.9	244.0	275	250	489.9
	460-3-60	414	506	3	26.9	179	3	30.8	229	7	2.9	201.1	225	225	391.6
	575-3-60	518	632		23.7	132		25.0	180		2.4	169.2	175	175	317.9
	380/415-3-50	342	440		26.9	174		30.8	229		2.9	201.1	225	225	391.6

## 38APD ELECTRICAL DATA — SINGLE POINT LOW SOUND FAN (cont)

38APD UNIT SIZE	V-Ph-Hz	SUPPLY VOLTAGE		COMPRESSOR						CONDENSER FAN		MCA	MOCP	REC FUSE	ICF
				Circuit A			Circuit B			Total Qty	FLA				
		Min	Max	Qty	RLA	LRA	Qty	RLA	LRA						
130	208/230-3-60	187	254		55.8	340		85.3	605		6.0	492.6	500	500	991.0
	380-3-60	342	418		34.0	196		51.9	380		3.9	301.9	300	300	617.0
	460-3-60	414	506	3	26.9	179	3	37.8	320	8	2.9	226.8	250	250	499.5
	575-3-60	518	632		23.7	132		34.6	250		2.4	202.8	225	225	409.5
	380/415-3-50	342	440		26.9	174		37.8	320		2.9	226.8	250	250	499.5

### LEGEND

- FLA** — Full Load Amps
- ICF** — Maximum Instantaneous Current Flow
- LRA** — Locked Rotor Amps
- MCA** — Minimum Circuit Amps
- MOCP** — Maximum Overcurrent Protection
- RLA** — Rated Load Amps

### NOTES:

1. Units are suitable for use on electrical systems where voltage supplied to the unit terminals is not below or above the listed minimum and maximum limits. Maximum allowable phase imbalance is: voltage 2%; amps 10%.
2. All units or modules have single point primary power connection. Main power must be supplied from a field-supplied disconnect.
3. For MCA that is less than or equal to 380 amps, 3 conductors are required.
4. For MCA between 381 and 760 amps, 6 conductors are required.
5. Calculation of conductors required is based on 75°C copper wire.
6. Wiring for main field supply must be rated 75°C. Use copper conductors only.
  - a. Incoming wire size range for terminal block with MCA up to 175 amps is 14 AWG (American Wire Gage) to 2/0.
  - b. Incoming wire size range for terminal block with MCA from 175.1 amps to 420 amps is 2 AWG to 600 kcmil.
  - c. Incoming wire size range for non-fused disconnect with MCA up to 100 amps is 14 AWG to 1/0.
  - d. Incoming wire size range for non-fused disconnect with MCA from 100.1 amps to 200 amps is 6 AWG to 350 kcmil.
  - e. Incoming wire size range for non-fused disconnect with MCA from 200.1 amps to 450 amps is 3/0 to 500 kcmil.



## 38APD115,130 ELECTRICAL DATA — DUAL POINT STANDARD FAN

38APD UNIT SIZE	V-Ph-Hz	SUPPLY VOLTAGE		COMPRESSOR						CONDENSER FAN		MCA	MOCP	REC FUSE	ICF
				Circuit A			Circuit B			Total Qty	FLA				
		Min	Max	Qty	RLA	LRA	Qty	RLA	LRA						
115 CIRCUIT 1	208/230-3-60	187	254		55.8	340		—	—	7	6.6	227.6	250	250	497.8
	380-3-60	342	418		34.0	196		—	—		3.9	137.8	150	150	291.3
	460-3-60	414	506	3	26.9	179	—	—	—		3.3	110.5	125	125	255.9
	575-3-60	518	632		23.7	132		—	—		2.6	95.2	110	110	197.6
	380/415-3-50	342	440		26.9	174		—	—		3.3	110.5	125	125	250.9
115 CIRCUIT 2	208/230-3-60	187	254		—	—		72.4	538	—	—	235.3	300	300	682.8
	380-3-60	342	418		—	—		35.3	290		—	114.7	150	150	360.6
	460-3-60	414	506	—	—	—	3	30.8	229		—	100.1	125	110	290.6
	575-3-60	518	632		—	—		25.0	180		—	81.3	100	90	230.0
	380/415-3-50	342	440		—	—		30.8	229		—	100.1	125	110	290.6
130 CIRCUIT 1	208/230-3-60	187	254		55.8	340		—	—	8	6.6	234.2	250	250	504.4
	380-3-60	342	418		34.0	196		—	—		3.9	141.7	175	175	295.2
	460-3-60	414	506	3	26.9	179	—	—	—		3.3	113.8	125	125	259.2
	575-3-60	518	632		23.7	132		—	—		2.6	97.8	110	110	200.2
	380/415-3-50	342	440		26.9	174		—	—		3.3	113.8	125	125	254.2
130 CIRCUIT 2	208/230-3-60	187	254		—	—		85.3	605	—	—	277.2	350	300	775.6
	380-3-60	342	418		—	—		51.9	380		—	168.7	200	200	483.8
	460-3-60	414	506	—	—	—	3	37.8	320		—	122.9	150	150	395.6
	575-3-60	518	632		—	—		34.6	250		—	112.5	125	125	319.2
	380/415-3-50	342	440		—	—		37.8	320		—	122.9	150	150	395.6

### LEGEND

- FLA** — Full Load Amps
- ICF** — Maximum Instantaneous Current Flow
- LRA** — Locked Rotor Amps
- MCA** — Minimum Circuit Amps
- MOCP** — Maximum Overcurrent Protection
- RLA** — Rated Load Amps

### NOTES:

1. Units are suitable for use on electrical systems where voltage supplied to the unit terminals is not below or above the listed minimum and maximum limits. Maximum allowable phase imbalance is: voltage 2%; amps 10%.
2. All units or modules have single point primary power connection. Main power must be supplied from a field-supplied disconnect.
3. For MCA that is less than or equal to 380 amps, 3 conductors are required.
4. For MCA between 381 and 760 amps, 6 conductors are required.
5. Calculation of conductors required is based on 75°C copper wire.

6. Wiring for main field supply must be rated 75°C. Use copper conductors only.

- a. Incoming wire size range for terminal block with MCA up to 175 amps is 14 AWG (American Wire Gage) to 2/0.
- b. Incoming wire size range for terminal block with MCA from 175.1 amps to 420 amps is 2 AWG to 600 kcmil.
- c. Incoming wire size range for non-fused disconnect with MCA up to 100 amps is 14 AWG to 1/0.
- d. Incoming wire size range for non-fused disconnect with MCA from 100.1 amps to 200 amps is 6 AWG to 350 kcmil.
- e. Incoming wire size range for non-fused disconnect with MCA from 200.1 amps to 450 amps is 3/0 to 500 kcmil.





## 38APD115,130 ELECTRICAL DATA — DUAL POINT LOW SOUND FAN

38APD UNIT SIZE	V-Ph-Hz	SUPPLY VOLTAGE		COMPRESSOR						CONDENSER FAN		MCA	MOCP	REC FUSE	ICF
				Circuit A			Circuit B			Total Qty	FLA				
		Min	Max	Qty	RLA	LRA	Qty	RLA	LRA						
115 CIRCUIT 1	208/230-3-60	187	254		55.8	340		—	—	7	6.0	223.4	250	250	493.6
	380-3-60	342	418		34.0	196		—	—		3.9	137.8	150	150	291.3
	460-3-60	414	506	3	26.9	179	—	—	—		2.9	107.7	125	125	253.1
	575-3-60	518	632		23.7	132		—	—		2.4	93.8	110	100	196.2
	380/415-3-50	342	440		26.9	174		—	—		2.9	107.7	125	125	248.1
115 CIRCUIT 2	208/230-3-60	187	254		—	—		72.4	538	—	—	235.3	300	300	682.8
	380-3-60	342	418		—	—		35.3	290		—	114.7	150	150	360.6
	460-3-60	414	506	—	—	—	3	30.8	229		—	100.1	125	110	290.6
	575-3-60	518	632		—	—		25.0	180		—	81.3	100	90	230.0
	380/415-3-50	342	440		—	—		30.8	229		—	100.1	125	110	290.6
130 CIRCUIT 1	208/230-3-60	187	254		55.8	340		—	—	8	6.0	229.4	250	250	499.6
	380-3-60	342	418		34.0	196		—	—		3.9	141.7	175	175	295.2
	460-3-60	414	506	3	26.9	179	—	—	—		2.9	110.6	125	125	256.0
	575-3-60	518	632		23.7	132		—	—		2.4	96.2	110	110	198.6
	380/415-3-50	342	440		26.9	174		—	—		2.9	110.6	125	125	251.0
130 CIRCUIT 2	208/230-3-60	187	254		—	—		85.3	605	—	—	277.2	350	300	775.6
	380-3-60	342	418		—	—		51.9	380		—	168.7	200	200	483.8
	460-3-60	414	506	—	—	—	3	37.8	320		—	122.9	150	150	395.6
	575-3-60	518	632		—	—		34.6	250		—	112.5	125	125	319.2
	380/415-3-50	342	440		—	—		37.8	320		—	122.9	150	150	395.6

### LEGEND

- FLA** — Full Load Amps
- ICF** — Maximum Instantaneous Current Flow
- LRA** — Locked Rotor Amps
- MCA** — Minimum Circuit Amps
- MOCP** — Maximum Overcurrent Protection
- RLA** — Rated Load Amps

### NOTES:

1. Units are suitable for use on electrical systems where voltage supplied to the unit terminals is not below or above the listed minimum and maximum limits. Maximum allowable phase imbalance is: voltage 2%; amps 10%.
2. All units or modules have single point primary power connection. Main power must be supplied from a field-supplied disconnect.
3. For MCA that is less than or equal to 380 amps, 3 conductors are required.
4. For MCA between 381 and 760 amps, 6 conductors are required.
5. Calculation of conductors required is based on 75°C copper wire.

6. Wiring for main field supply must be rated 75°C. Use copper conductors only.

- a. Incoming wire size range for terminal block with MCA up to 175 amps is 14 AWG (American Wire Gage) to 2/0.
- b. Incoming wire size range for terminal block with MCA from 175.1 amps to 420 amps is 2 AWG to 600 kcmil.
- c. Incoming wire size range for non-fused disconnect with MCA up to 100 amps is 14 AWG to 1/0.
- d. Incoming wire size range for non-fused disconnect with MCA from 100.1 amps to 200 amps is 6 AWG to 350 kcmil.
- e. Incoming wire size range for non-fused disconnect with MCA from 200.1 amps to 450 amps is 3/0 to 500 kcmil.



## Microprocessor

The *ComfortLink* microprocessor controls overall unit operation. Its central executive routine controls a number of processes simultaneously. These include internal timers, reading inputs, analog to digital conversions, fan control, display control, diagnostic control, output relay control, demand limit, capacity control, head pressure control, and temperature reset. Some processes are updated almost continuously, others every 2 to 3 seconds, and some every 30 seconds. The microprocessor also has the capability of communicating with the Carrier Comfort Network® (CCN) devices using the CCN protocol and when the accessory translator is used, other popular protocols including BACnet, Modbus<sup>1</sup>, and LonWorks may also be used.

The microprocessor routine is started by switching the Emergency ON-OFF switch to ON position.

## Cooling control options

When mechanical cooling is required *ComfortLink* controls have the capability to control the staging of the compressors in several different ways. The control checks on various other operation parameters in the units to make sure that safety limits are not exceeded and the compressors are reliably operated.

The 38AP unit's *ComfortLink* controls offer two basic control approaches to mechanical cooling: constant volume (CV) with 2 stages of cooling, and variable air volume (VAV) with multiple stages of cooling. In addition to these traditional methods of control, the 38AP Series *ComfortLink* controls offer the ability to run multiple stages of cooling in constant volume applications and accept an external input for desired percentage of capacity.

CONTROL TYPE	COOLING CONTROL METHOD	UNIT SIZE	STAGING CONTROLLED BY
CV THERMOSTAT 2-STAGE	Thermostat	025 to 030	2-Stage Thermostat
CV THERMOSTAT MULTIPLE STAGE	Thermostat	025 to 130	Supply Air Temperature
CV SPT MULTIPLE STAGE	Space Temperature, T-55/T-56	025 to 130	Supply Air Temperature
VAV	Supply Air Temperature	025 to 130	Supply Air Temperature
% CAPACITY	4-20 mA Input	025 to 130	Supply Air Temperature

### LEGEND

- CV — Constant Volume
- SPT — Space Temperature Sensor
- VAV — Variable Air Volume

## High-efficiency variable condenser fans (38AP units with Greenspeed® intelligence only)

All fans on a circuit run at the same speed and are controlled by a VFD with special CCN software to maintain SCT (saturated condensing temperature) set point. The set point is calculated from operating conditions and adjusted to the most efficient operating point. The high-efficiency variable condenser fan option uses Danfoss VLT 102 variable frequency drives, each with a display. Drives are connected to the LEN communication bus. Fan speed is determined by the unit controller and communicated to the drive to provide excellent part load efficiency and reduced sound level operation over the life of the condensing unit.

1. Third-party trademarks and logos are property of their respective owners.

## Digital compressor

The 38AP units offer a digital compressor factory-installed option composed of one digital compressor per unit to operate in combination with the remaining standard scroll compressor(s). The digital compressor has the ability to load and unload rapidly, and the load/unload timing can be varied to achieve unit capacity and closely match the load. The digital scroll option provides better capacity control by digitally modulating capacity, effectively increasing the number of compression stages. The digital scroll compressor modulates the capacity output using a digital unloader solenoid (DUS) which is activated by a signal from the *ComfortLink* controller to allow the scroll sets to rapidly separate (stop compressing) and reengage (resume compressing) during operation. Supply and return air sensors provide the input to the *ComfortLink* controller necessary to stage unloading for all digital compressor units. The % capacity control function does not require input from supply and return air sensors. Refer to pages 35-42 for typical control wiring schematics of various common applications. The digital scroll operates in two stages, the loaded state when the solenoid valve is normally closed and the unloaded state when the solenoid valve is energized. These two states rapidly alternate between full capacity and zero capacity where during the loaded state the compressor operates like a standard scroll and delivers full capacity and mass flow, and during the unloaded state, the compressor does not flow refrigerant. The timing of the load/unload states is then tuned to match the desired output.

## Control type

The control type determines the selection of the type of cooling control as well as the technique for selecting a cooling mode. The control types are:

### VAV

This configuration refers to standard VAV operation. If the control is occupied and fan status input closed, the controls vary capacity based on supply-air temperature.

### CV TSTAT-2 Stage

This configuration will force the control to monitor the thermostat inputs (Y1,Y2) to make a determination of mode and capacity.

### CV TSTAT-Multiple Stage

This configuration will force the control to monitor the thermostat inputs (Y1,Y2) to make a determination of mode. Unlike traditional 2-stage thermostat control, the unit is allowed to use multiple stages of cooling control and perform VAV-style capacity control.

### CV SPT-Multiple Stage

This configuration will force the control to monitor a space temperature sensor to make a determination of mode. The unit is allowed to use multiple stages of cooling control and perform VAV-style capacity control.

### % Capacity Control

This configuration will force the control to monitor a 4 to 20 mA external input and vary compressor capacity from 0 to 100% depending on the 4 to 20 mA input.

## Cooling control method

Three different cooling control methods are used to step through the available stages of capacity depending on the unit size, circuiting, compressor type and cooling control

method. Refer to Loading Sequences tables in the Application Data section on page 44 for specific capacity control.

## Multiple-Stage Supply Air Temperature (SAT)

The capacity of the compressors are controlled based on the supply-air temperature and supply air temperature set point. This control method uses an adaptive PID (proportional, integral, derivative) algorithm to calculate the estimated change in supply-air temperature before engaging or disengaging the next stage of cooling. The algorithm compensates for varying conditions, including changing flow rates across the evaporator coil, to provide better overall control of compressor staging.

## Multiple Adaptive Demand

This control method will base the capacity compressors on the supply air discharge temperature and one of two supply air temperature set points. The control will be able to call out a LOW COOL or a HIGH COOL mode and maintain a low or high cool supply air set point. The unit will use either the input from a conventional thermostat to turn the Y1, Y2 signals into a high and low demand signal, or with a space temperature sensor use a differential from set point to determine the mode. Once the mode has been established the control uses the same algorithm as with VAV control.

## Two-Stage Demand

The unit will operate 2 stages of compressor capacity control.

## Demand limiting

The control supports demand limiting using one or two fixed capacity limits initiated by discrete input switches or a variable capacity limit function based on an analog input signal. On CCN systems this can be done through the network, or for non-CCN network jobs this can be done by adding the energy management module.

## Diagnostics

The *ComfortLink* controls have fully integrated all controls and sensors into a common control system. The control monitors these inputs as well as many of the routines to provide advanced diagnostics. These include adaptive logic to allow the unit to continue to operate in a reduced output mode and automatic resets where applicable. The last 10 alarms and alerts are stored in memory and can be accessed through the display. The alarms can also be monitored through the Carrier Comfort Network<sup>®</sup> connection. The unit also supports the use of the hand held Navigator<sup>™</sup> display which can be plugged in at the main control box.

Some of the diagnostics that are included are:

- Monitoring of all sensors
- Suction and discharge pressure transducers to provide compressor protection and coil freeze protection
- Monitoring of compressor status using compressor protection boards
- Low refrigerant charge protection
- Compressor reverse rotation protection
- Low superheat protection

## Control interface

The *ComfortLink* controller can interface with the Carrier Comfort Network devices through the 485 communications port. This will allow for the use of all system control programs. These include:

- Network Service Tool

- Touch Pilot<sup>™</sup> device
- ComfortVIEW<sup>™</sup> software
- CCN Web software

The control can also provide interface with non-Carrier energy management systems with the addition of either the BACnet/MODBUS Carrier translator or the LonWorks Carrier translator. Several contact connection points have been provided in the main control box for interface to external controls and systems.

## Constant volume applications

The units can be configured to operate in CV applications. The unit operates with either a standard (mechanical or electronic) 2-stage cool thermostat, or with an electronic room temperature sensor and a timeclock to establish unit start and stop times. With a standard thermostat (programmable is optional), cooling operation is set by space temperature. With a space sensor and field-supplied timeclock, the machine will operate at default values unless they are changed using appropriate input devices.

Features with thermostat control of unit include:

- Two-stage cooling or adaptive multiple stage cooling which can provide 2 to 6 stages of capacity when supply air sensors installed. Refer to Loading Sequences tables in the Application Data section on page 44 for specific capacity control.
- Control of unit using Y1, Y2 thermostat or T55, T56, or T58 space sensors.
- Control of a condenser fan based on outdoor-air and condensing pressures.
- Compressor time guard override (power up and minimum on and off timers) to assure air return in low load conditions.
- Features with sensor control (three options available) of unit include:
  - T55 sensor will monitor room temperature and provide unoccupied override capability (1 to 4 hours).
  - T56 sensor will monitor room temperature, provide unoccupied override capability (1 to 4 hours), and provide a temperature offset of 5°F (2.7°C) maximum.
  - T58 CCN communicating sensor will provide the set point and space temperature values.

Standard features include:

- Two-stage cooling or adaptive multiple stage cooling which can provide 2 to 6 stages of capacity when supply air sensors installed. Refer to Loading Sequences tables in the Application Data section on page 44 for specific capacity control.
- Adjustment of space temperature set points of  $\pm 5^\circ\text{F}$  (2.7°C) when using a T56 sensor.
- 365-day timeclock with backup (supports minute, hour, and day of week, date, month, and year access). The timeclock includes the following features:
  - Daylight savings time function
  - Occupancy control with 8 periods for unit operation
  - Holiday table containing up to 18 holiday schedules
- Ability to initiate timed override from T55 or T56 sensors (for a timed period of 1 to 4 hours).
- For units connected into a CCN network the timeclock can be integrated into the overall building energy management system and be updated remotely.

## Variable air volume (VAV) applications

Units that are configured to operate in VAV applications are designed to control the leaving-air temperature in cooling to a configurable set point. Some of the features for VAV units in a stand-alone application include:

- The units are shipped as operable, stand-alone units with the addition of a field-supplied timeclock to establish unit start and stop times or they can use *ComfortLink* time of day scheduling routine.
- Provide cooling control.
- Supports an optional space temperature sensor for mode control and supply air temperature reset.
- If space sensor is equipped with an override feature, the sensor will allow operation during the unoccupied period for a fixed length of time.
- Control board diagnostics.
- Control of an outdoor-air fan based upon outdoor-air temperature and saturated condensing temperature.
- Support of remote occupied/unoccupied input to start.
- Support a field test for field check out.
- Cooling capacity control of 2 to 6 stages plus economizer. Refer to Loading Sequences tables in the Application Data section on page 44 for specific capacity control.
- Compressor time delays to prevent rapid cycling of compressors.
- Automatic lead-lag control of compressors to reduce the number of compressor cycles. (When unit is equipped with digital scroll option, Sequence A is always used.)
- With the addition of the energy management board, the *ComfortLink* controls will also support demand limiting and remote set point control.

When the unit is connected to a CCN (Carrier Comfort Network®) system, the following additional features can be used:

- Interface of the unit clock with the CCN network clock and allow for remote configuration of the schedules.
- CCN demand limit participation.

## Sequence of operation

### Cooling, constant volume (CV) units

On power up, the control module will activate the initialization software. The initialization software will determine the

unit configuration and also initialize any controls loops and input/output devices. All alarms and configurations are saved in memory and maintained during power outages. All alarms will be maintained in memory and must be cleared through the display.

### Constant volume conventional thermostat control

If the unit is equipped with a conventional thermostat with Y1, Y2 connections, then the control will perform the following sequence.

If Y1 is closed and the fan status input is closed then the control will stage the first compressor be sequenced on. If Y2 closes the control will stage the second compressor on. For units configured for TSTAT Multi, the control will add and remove compressor stages to maintain the low and high demand leaving air set points. If Y1 is closed at least one compressor stage will be turned on.

### Constant volume space temperature sensor control

If the space temperature operation has been selected using a T55, T56, or T58 sensor then the following logic will be used to control the operation of the unit. If the internal timeclock is used, the control module determines the occupancy state based on the system time schedules. The set point for cooling is configurable through the display. If a T56 sensor is being used then the set point can be shifted by as much as 5 degrees. If the space temperature goes above the cooling set point then the unit will go into Cooling mode. The set point will depend on the space temperature. Once the fan status input is closed then the compressors will be sequenced on to maintain either the low or high load temperature set points.

### Variable air volume control

On power up, the control module will activate the initialization software. The initialization software will determine the unit configuration and also initialize any controls loops and input/output devices. All alarms and configurations are saved in memory and maintained during power outages. All alarms will be maintained in memory and must be cleared through the display.

The unit will first determine the mode of operation. If the Cooling mode is required and the fan status input closed, then the controlling set point will be the leaving air temperature set point; then the leaving-air temperature will sequence to compressors on and off using a PID control loop.

## FIELD POWER WIRING

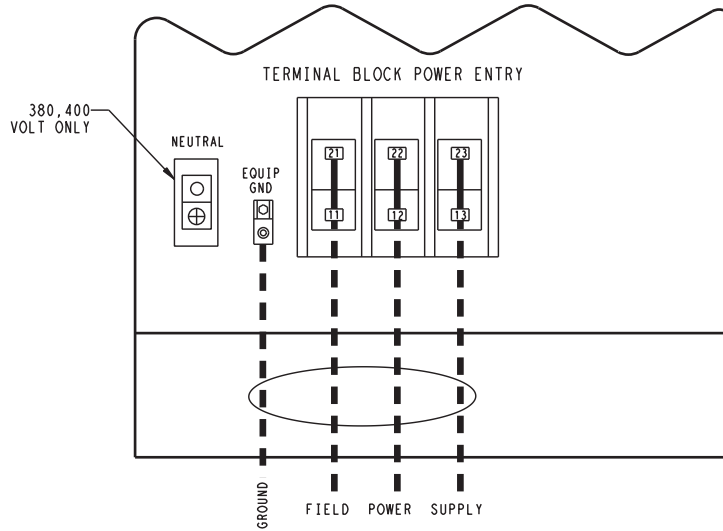

DISCONNECT/BRANCH CIRCUIT PROTECTION PER NEC  
(SEE NOTE #3)  
**TERMINAL BLOCK**

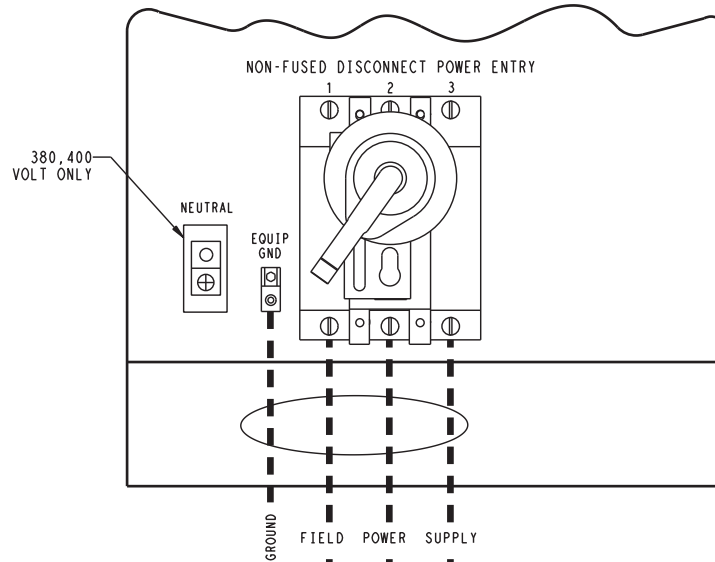

DISCONNECT/BRANCH CIRCUIT PROTECTION PER NEC  
(SEE NOTE #3)  
**NON-FUSED DISCONNECT**

**LEGEND**

**EQUIP GND** — Equipment Ground  
**NEC** — National Electrical Code

**NOTES:**

1. Factory wiring is in accordance with UL 1995 standards. Field modifications or additions must be in compliance with all applicable codes.
2. All units or modules have single point primary power connection. Main power must be supplied from a field or factory-supplied disconnect.
3. Wiring for main field supply must be rated 75°C. Use copper conductors only.

4. Incoming wire size range for terminal block with MCA (minimum circuit amps) up to 175 amps is 14 AWG (American Wire Gage) to 2/0.
  - a. Incoming wire size range for terminal block with MCA from 175.1 amps to 420 amps is 2 AWG to 600 kcmil.
  - b. Incoming wire size range for non-fused disconnect with MCA up to 100 amps is 14 AWG to 1/0.
  - c. Incoming wire size range for non-fused disconnect with MCA from 100.1 amps to 200 amps is 6 AWG to 350 kcmil.
  - d. Incoming wire size range for non-fused disconnect with MCA from 200.1 amps to 450 amps is 3/0 to 500 kcmil.
5. Refer to certified dimensional drawings for exact locations of the main power and control power entrance locations.



## VARIABLE AIR VOLUME APPLICATION WIRING DIAGRAM, C.TYP=1 (VAV), DIGITAL AND NON-DIGITAL, SIZES 025-130

- NOTES:**
- Field Wiring must be in accordance with local codes.
  - LVT-1 and LVT-2 are for an Alarm Relay. The maximum load allowed for the Alarm Relay is 5 VA sealed, 10 VA inrush at 24 VAC. Field Supplied power is not required.
  - LVT-24, -25 and -2 are for control of field-supplied Liquid Line Solenoid Valves (LLSV). The contacts are rated for 15 VA sealed, 30 VA inrush at 24 VAC. Field Supplied power is not required.
  - For 38APD070-130 units, additional LLSV can be connected to CXB-J6-5, -6 and -7. The contacts are rated for 15 VA sealed, 30 VA inrush at 24 VAC. A field-supplied control transformer is required, not to exceed 75 VA.
  - All discrete inputs, Remote ON-OFF, Fan Status Switch (FS1), and Demand Limit Switch 1 and 2 must be rated for dry circuit applications, 24 VAC load up to 50 mA.
  - Installation of Fan Status Switch (FS1) is required.
  - Energy Management Module (EMM) is required for 4-20 mA Demand Limit, Single or Two-Step Demand Limit, or 4-20 mA Temperature Reset.
  - Mixed Air/Return Air, Supply Air and Space Temperature inputs can be communicated to the unit controls. Thermistor inputs are preferred method.

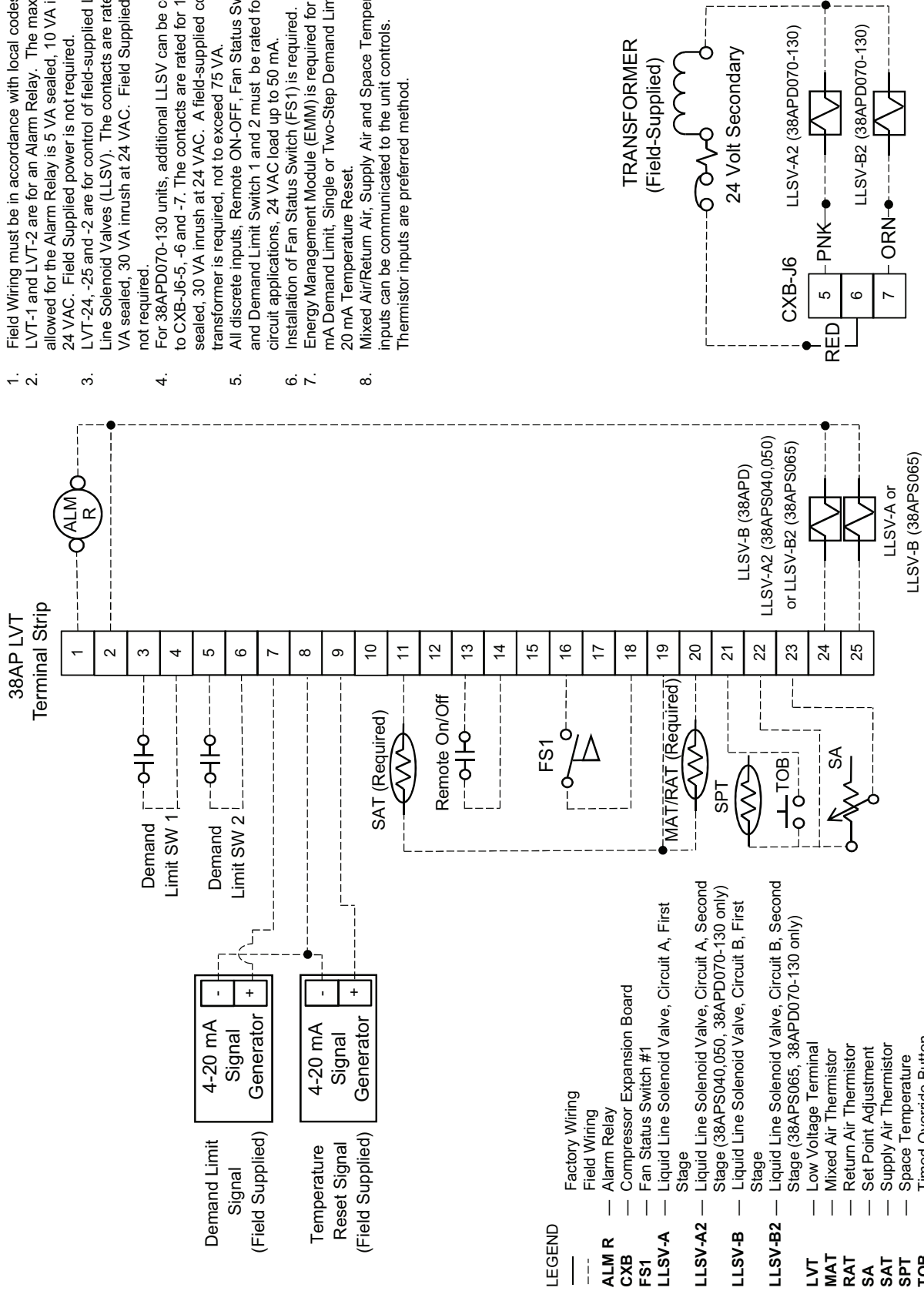



## CONSTANT VOLUME APPLICATION WIRING DIAGRAM THERMOSTAT MULTIPLE STAGES, C.TYP-3 (TSTAT MULTI), DIGITAL SIZES 025-130, NON-DIGITAL SIZES 040-130

### NOTES:

1. Field Wiring must be in accordance with local codes.
2. LVT-1 and LVT-2 are for an Alarm Relay. The maximum load allowed for the Alarm Relay is 5 VA sealed, 10 VA inrush at 24 VAC. Field Supplied power is not required.
3. LVT-24, -25 and -2 are for control of field-supplied Liquid Line Solenoid Valves (LLSV). The contacts are rated for 15 VA sealed, 30 VA inrush at 24 VAC. Field Supplied power is not required.
4. For 38APD070-130 units, additional LLSV can be connected to CXB-J6-5, -6 and -7. The contacts are rated for 15 VA sealed, 30 VA inrush at 24 VAC. A field-supplied control transformer is required, not to exceed 75 VA.
5. All discrete inputs, Remote ON-OFF, Fan Status Switch (FS1), and Demand Limit Switch 1 and 2 must be rated for dry circuit applications, 24 VAC load up to 50 mA.
6. Installation of Fan Status Switch (FS1) is required.
7. Energy Management Module (EMM) is required for 4-20 mA Demand Limit, Single or Two-Step Demand Limit, or 4-20 mA Temperature Reset.
8. Mixed Air/Return Air, Supply Air and Space Temperature inputs can be communicated to the unit controls. Thermistor inputs are preferred method.

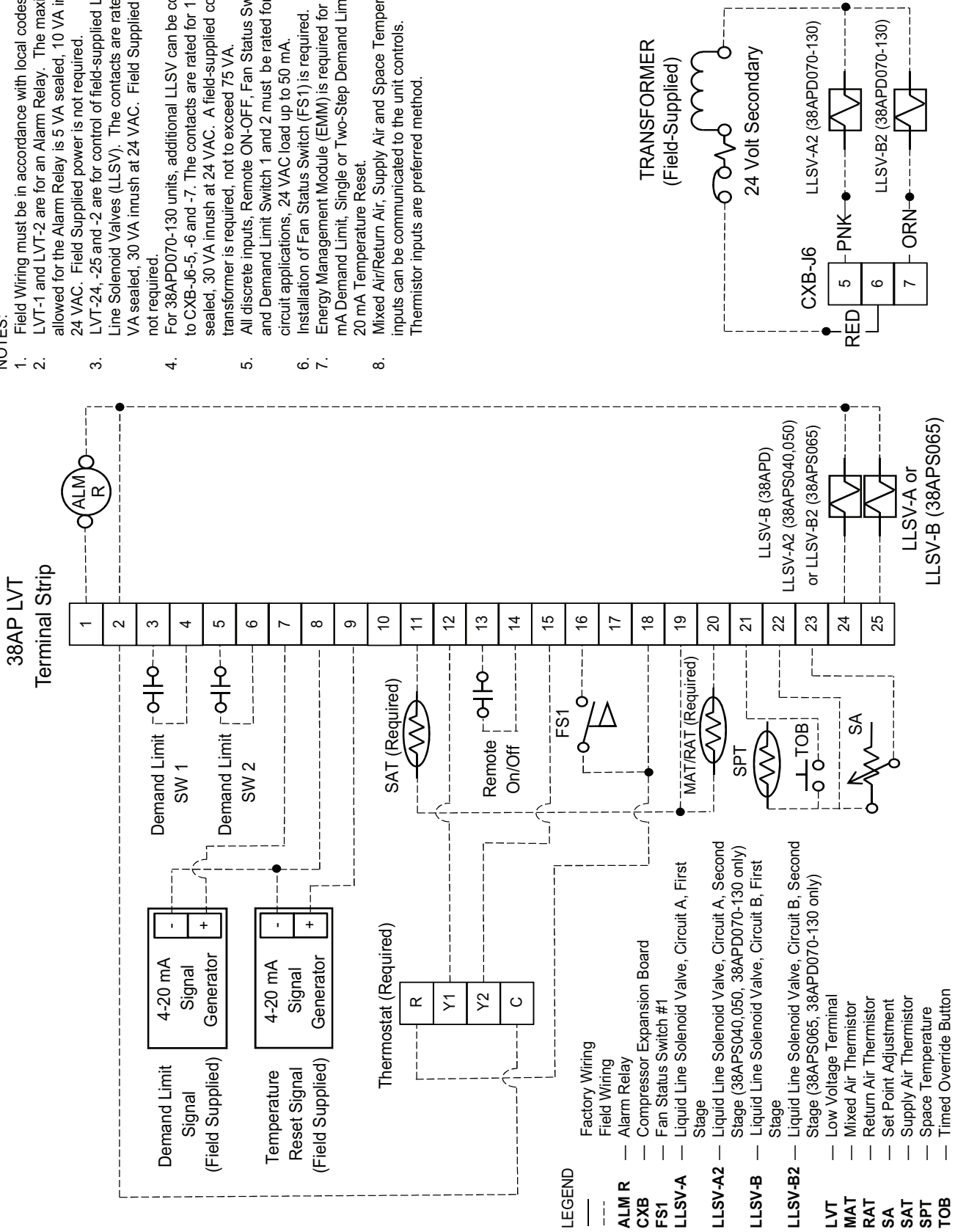

## CONSTANT VOLUME APPLICATION WIRING DIAGRAM 2-STAGE THERMOSTAT CONTROL, C.TYP=4 (TSTAT 2STG), NON-DIGITAL, SIZES 025-030

### NOTES:

- Field Wiring must be in accordance with local codes.
- LVT-1 and LVT-2 are for an Alarm Relay. The maximum load allowed for the Alarm Relay is 5 VA sealed, 10 VA inrush at 24 VAC. Field Supplied power is not required.
- LVT-24, -25 and -2 are for control of field-supplied Liquid Line Solenoid Valves (LLSV). The contacts are rated for 15 VA sealed, 30 VA inrush at 24 VAC. Field Supplied power is not required.
- For 38APD070-130 units, additional LLSV can be connected to CXB-J6-5, -6 and -7. The contacts are rated for 15 VA sealed, 30 VA inrush at 24 VAC. A field-supplied control transformer is required, not to exceed 75 VA.
- All discrete inputs, Remote ON-OFF, Fan Status Switch (FS1), and Demand Limit Switch 1 and 2 must be rated for dry circuit applications, 24 VAC load up to 50 mA.
- Installation of Fan Status Switch (FS1) is required.
- Energy Management Module (EMM) is required for 4-20 mA Demand Limit, Single or Two-Step Demand Limit.
- This control scheme does not support digital compressor or minimum load control operation.
- This control scheme is not recommended for 38APD040-130 and 38APS040-065 units since there are more than 2 stages of capacity available.
- Mixed Air/Return Air, Supply Air and Space Temperature are not required for this control scheme. Although not required Mixed Air/Return Air, Supply Air and Space Temperature inputs can be communicated to the unit controls. Thermistor inputs are preferred over communication.

### 38AP LVT Terminal Strip

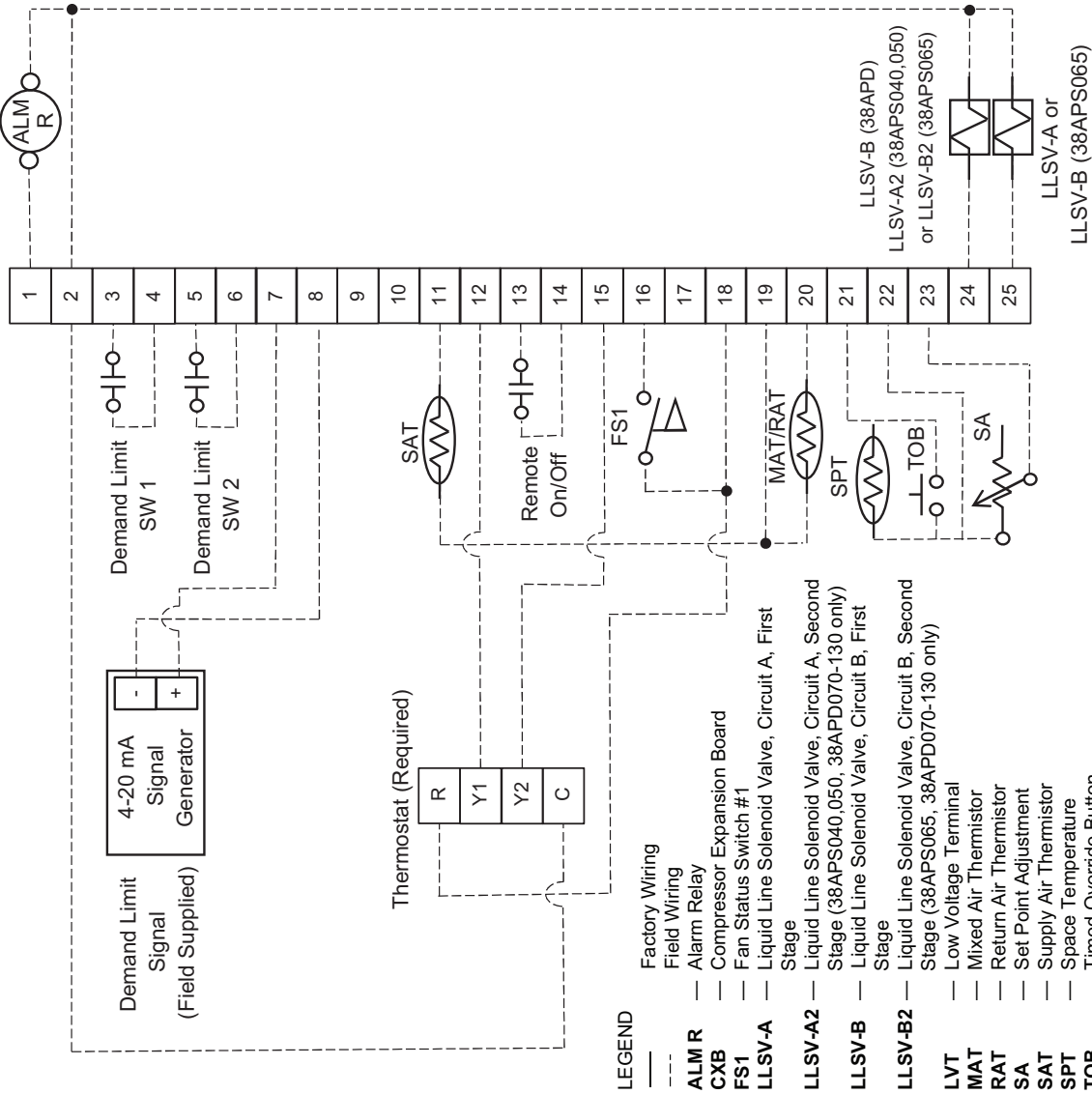

## CONSTANT VOLUME APPLICATION WIRING DIAGRAM SPACE TEMPERATURE SENSOR CONTROL, C.TYP-5 (SPT MULTI), DIGITAL AND NON-DIGITAL, SIZES 025-130

### NOTES:

1. Field Wiring must be in accordance with local codes.
2. LVT-1 and LVT-2 are for an Alarm Relay. The maximum load allowed for the Alarm Relay is 5 VA sealed, 10 VA inrush at 24 VAC. Field Supplied power is not required.
3. LVT-24, -25 and -2 are for control of field-supplied Liquid Line Solenoid Valves (LLSV). The contacts are rated for 15 VA sealed, 30 VA inrush at 24 VAC. Field Supplied power is not required.
4. In order to use 4-20 mA Space Temperature Setpoint, unit Main Base Board (MBS) software must be Version 7.0 or higher. The use of 4-20 mA Space Temperature Setpoint with 4-20 mA Temperature Reset is not recommended.
5. For 38APD070-130 units, additional LLSV can be connected to CXB-J6-5, -6 and -7. The contacts are rated for 15 VA sealed, 30 VA inrush at 24 VAC. A field-supplied control transformer is required, not to exceed 75 VA.
6. All discrete inputs, Remote ON-OFF, Fan Status Switch (FS1), and Demand Limit Switch 1 and 2 must be rated for dry circuit applications, 24 VAC load up to 50 mA.
7. Installation of Fan Status Switch (FS1) is required.
8. Energy Management Module (EMM) is required for 4-20 mA Space Temperature Setpoint, 4-20 mA Demand Limit, Single or Two-Step Demand Limit, 4-20 mA Temperature Reset, or 4-20 mA Space Temperature Setpoint.
9. Mixed Air/Return Air, Supply Air and Space Temperature inputs can be communicated to the unit controls. Thermistor inputs are preferred method.

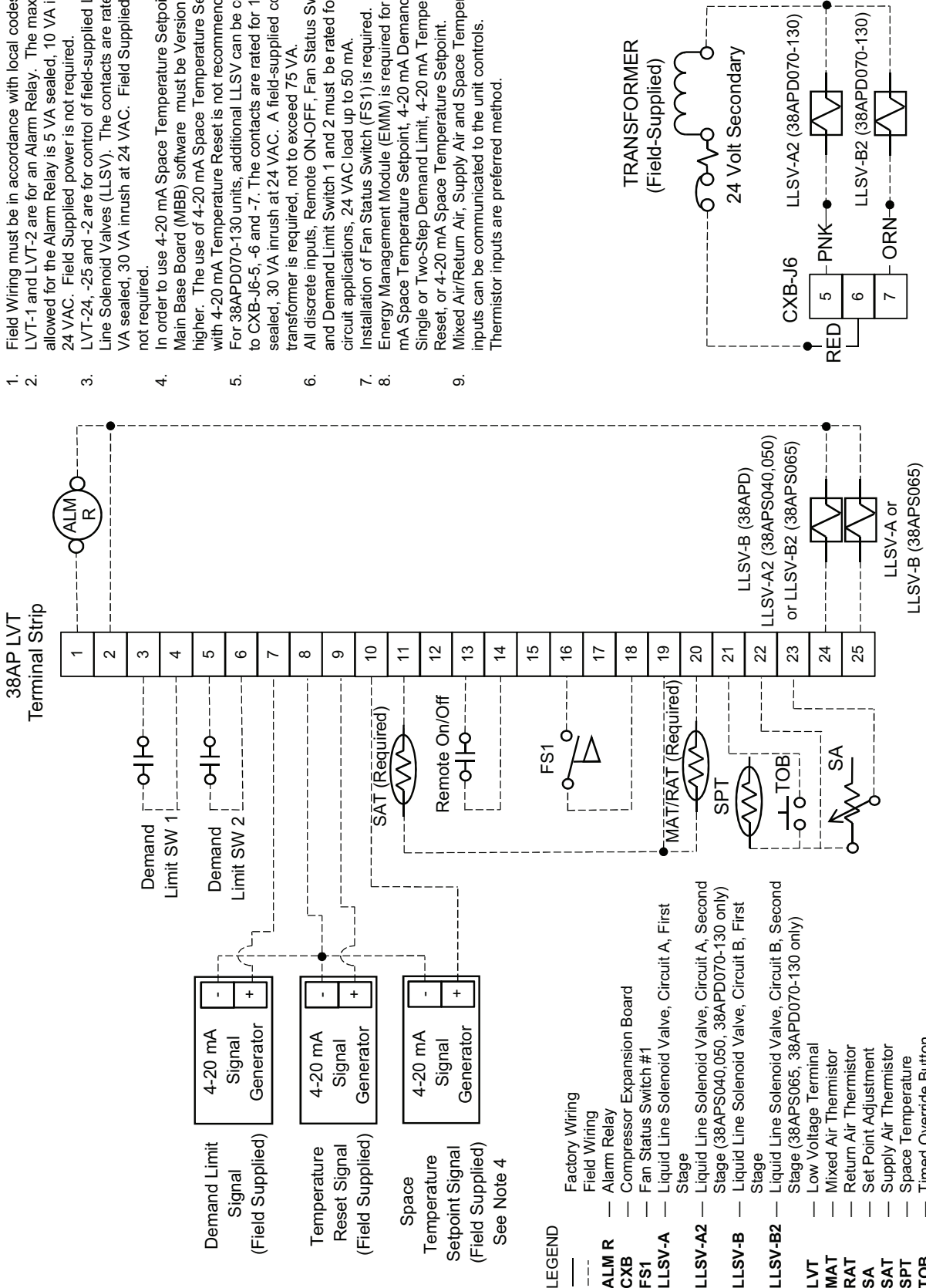

### LEGEND

- Factory Wiring
- - - Field Wiring
- ALM R — Alarm Relay
- CXB — Compressor Expansion Board
- FS1 — Fan Status Switch #1
- LLSV-A — Liquid Line Solenoid Valve, Circuit A, First Stage
- LLSV-A2 — Liquid Line Solenoid Valve, Circuit A, Second Stage (38APS040,050, 38APD070-130 only)
- LLSV-B — Liquid Line Solenoid Valve, Circuit B, First Stage
- LLSV-B2 — Liquid Line Solenoid Valve, Circuit B, Second Stage (38APS065, 38APD070-130 only)
- LVT — Low Voltage Terminal
- MAT — Mixed Air Thermistor
- RAT — Return Air Thermistor
- SA — Set Point Adjustment
- SAT — Supply Air Thermistor
- SPT — Space Temperature
- TOB — Timed Override Button

### TRANSFORMER (Field-Supplied)

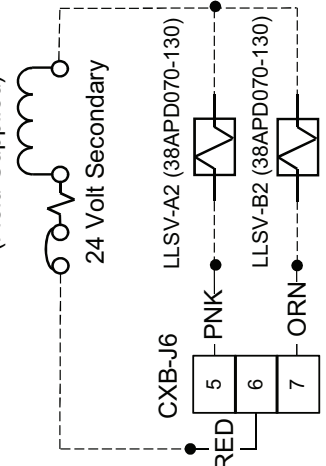

## PERCENT CAPACITY APPLICATION WIRING DIAGRAM, C.TYP=7 (PCT CAP), DIGITAL AND NON-DIGITAL, SIZES 025-130

### NOTES:

1. Field Wiring must be in accordance with local codes.
2. LVT-1 and LVT-2 are for an Alarm Relay. The maximum load allowed for the Alarm Relay is 5 VA, sealed, 10 VA inrush at 24 VAC. Field Supplied power is not required.
3. LVT-24, -25 and -2 are for control of field-supplied Liquid Line Solenoid Valves (LLSV). The contacts are rated for 15 VA sealed, 30 VA inrush at 24 VAC. Field Supplied power is not required.
4. For 38APD070-130 units, additional LLSV can be connected to CXB-J6-5, -6 and -7. The contacts are rated for 15 VA sealed, 30 VA inrush at 24 VAC. A field-supplied control transformer is required, not to exceed 75 VA.
5. All discrete inputs, Remote ON-OFF and Fan Status Switch (FS1) must be rated for dry circuit applications, 24 VAC load up to 50 mA.
6. Installation of Fan Status Switch (FS1) is required.
7. Energy Management Module (EMM) is required for this Control Type.
8. Mixed Air/Return Air, Supply Air and Space Temperature inputs can be communicated to the unit controls. Thermistor inputs are preferred method.

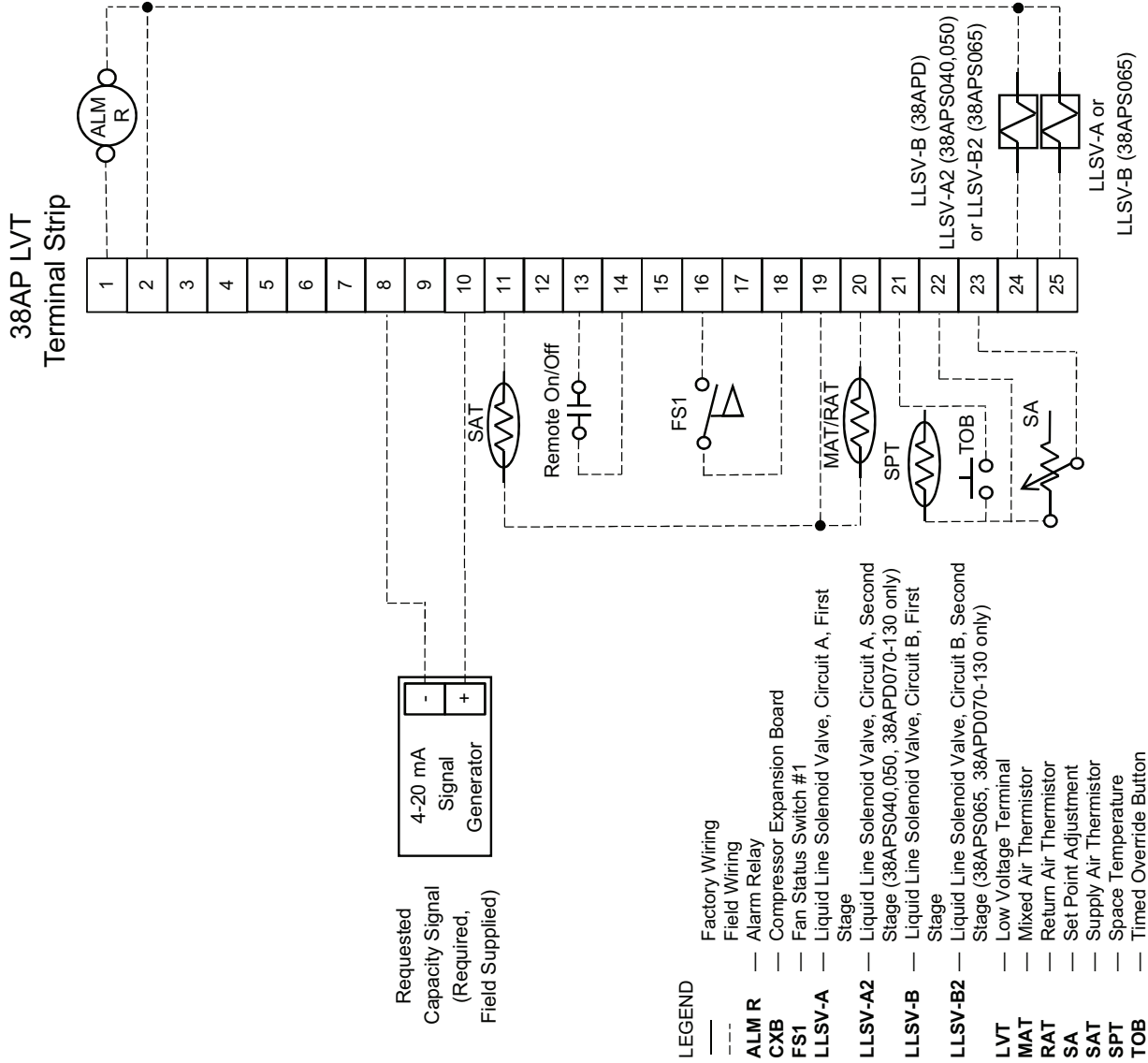

# Typical control wiring schematics (cont)



## INDEPENDENT DUAL CIRCUIT CONTROL, C.TYP=8 (DUAL TSTAT), DUAL CIRCUIT NON-DIGITAL SIZES 040-130

### NOTES:

1. Field Wiring must be in accordance with local codes.
2. LVT-1 and LVT-2 are for an Alarm Relay. The maximum load allowed for the Alarm Relay is 5 VA sealed, 10 VA inrush at 24 VAC. Field Supplied power is not required.
3. LVT-24, -25 and -2 are for control of field-supplied Liquid Line Solenoid Valves (LLSV). The contacts are rated for 15 VA sealed, 30 VA inrush at 24 VAC. Field Supplied power is not required.
4. For 38APD070-130 units, additional LLSV can be connected to CXB-J6-5, -6 and -7. The contacts are rated for 15 VA sealed, 30 VA inrush at 24 VAC. A field-supplied control transformer is required, not to exceed 75 VA.
5. All discrete inputs, Remote ON-OFF, Fan Status Switches (FS1 and FS2), and Thermostat Relays (T1 and T2) must be rated for dry circuit applications, 24 VAC load up to 50 mA.
6. Installation of Fan Status Switches (FS1 and FS2) are required.
7. Energy Management Module (EMM) is required for the Control Type, as well as 4-20 mA Demand Limit.
8. Single or Two-Step Demand Limit is not allowed for this Control Type.
9. This control scheme does not support digital compressor or minimum load control operation.
10. This control scheme is not recommended for units with more than 4 stages of capacity, 38APD070-130.
11. This control scheme is not allowed for single circuit units, 38APS025-065.

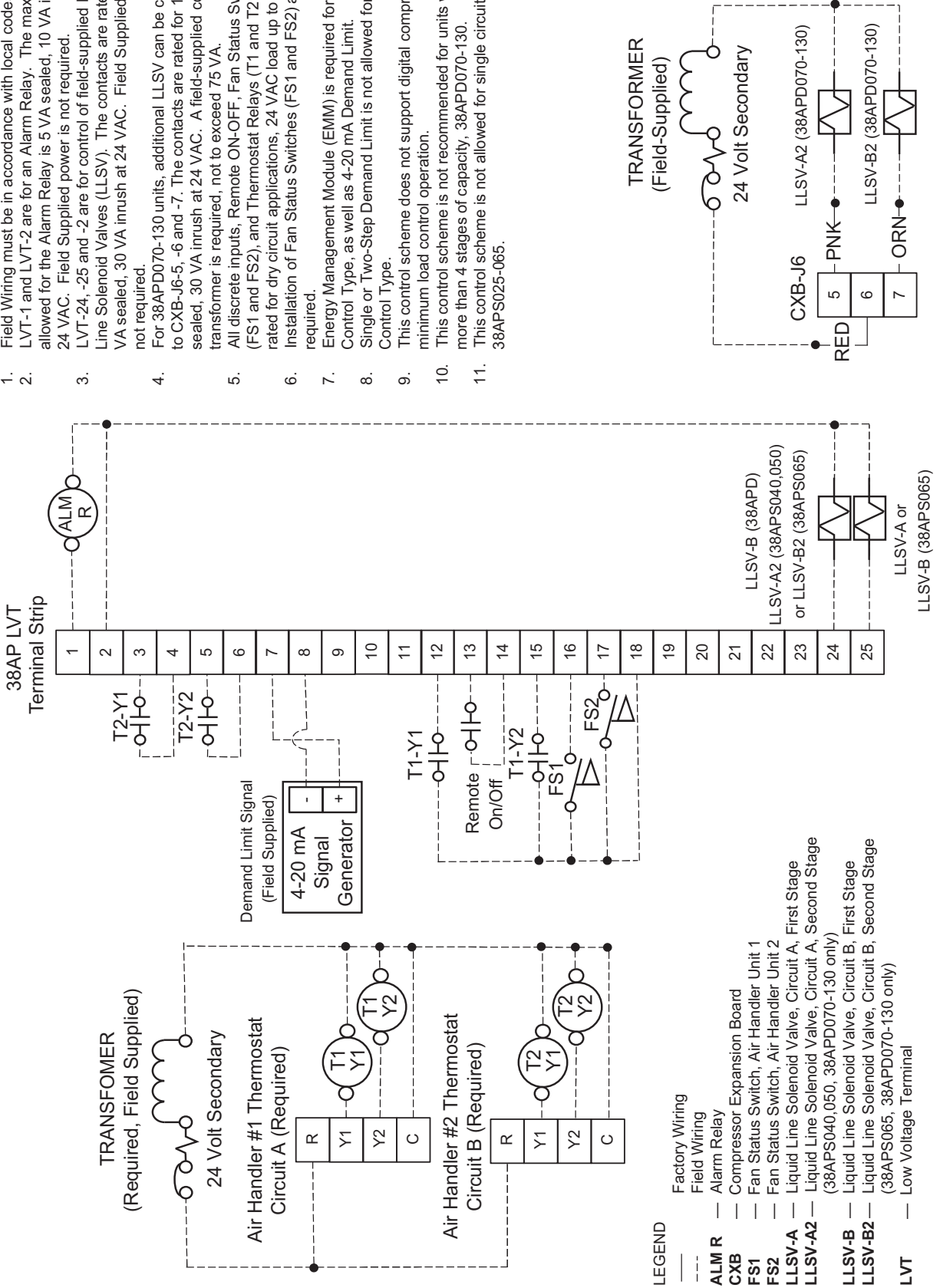

- LEGEND**
- Factory Wiring
  - - - Field Wiring
  - ALM R — Alarm Relay
  - CXB — Compressor Expansion Board
  - FS1 — Fan Status Switch, Air Handler Unit 1
  - FS2 — Fan Status Switch, Air Handler Unit 2
  - LLSV-A — Liquid Line Solenoid Valve, Circuit A, First Stage (38APS040,050, 38APD070-130 only)
  - LLSV-A2 — Liquid Line Solenoid Valve, Circuit A, Second Stage (38APS040,050, 38APD070-130 only)
  - LLSV-B — Liquid Line Solenoid Valve, Circuit B, First Stage
  - LLSV-B2 — Liquid Line Solenoid Valve, Circuit B, Second Stage (38APS065, 38APD070-130 only)
  - LVT — Low Voltage Terminal

# Typical control wiring schematics (cont)



## VARIABLE AIR VOLUME SETPOINT CONTROL APPLICATION WIRING DIAGRAM, C.TYP=9 (VAV SETPOINT), DIGITAL AND NON-DIGITAL, SIZES 025-130

### NOTES:

1. Field Wiring must be in accordance with local codes.
2. LVT-1 and LVT-2 are for an Alarm Relay. The maximum load allowed for the Alarm Relay is 5 VA sealed, 10 VA inrush at 24 VAC. Field Supplied power is not required.
3. LVT-24, -25 and -2 are for control of field-supplied Liquid Line Solenoid Valves (LLSV). The contacts are rated for 15 VA sealed, 30 VA inrush at 24 VAC. Field Supplied power is not required.
4. For 38APD070-130 units, additional LLSV can be connected to CXB-J6-5, -6 and -7. The contacts are rated for 15 VA sealed, 30 VA inrush at 24 VAC. A field-supplied control transformer is required, not to exceed 75 VA.
5. All discrete inputs, Remote ON-OFF, Fan Status Switch (FS1), and Demand Limit Switch 1 and 2 must be rated for dry circuit applications, 24 VAC load up to 50 mA.
6. Installation of Fan Status Switch (FS1) is required.
7. Energy Management Module (EMM) is required for 4-20 mA Setpoint, 4-20 mA Demand Limit, Single or Two-Step Demand Limit, or 4-20 mA Temperature Reset.
8. Mixed Air/Return Air, Supply Air and Space Temperature inputs can be communicated to the unit controls. Thermistor inputs are preferred method.

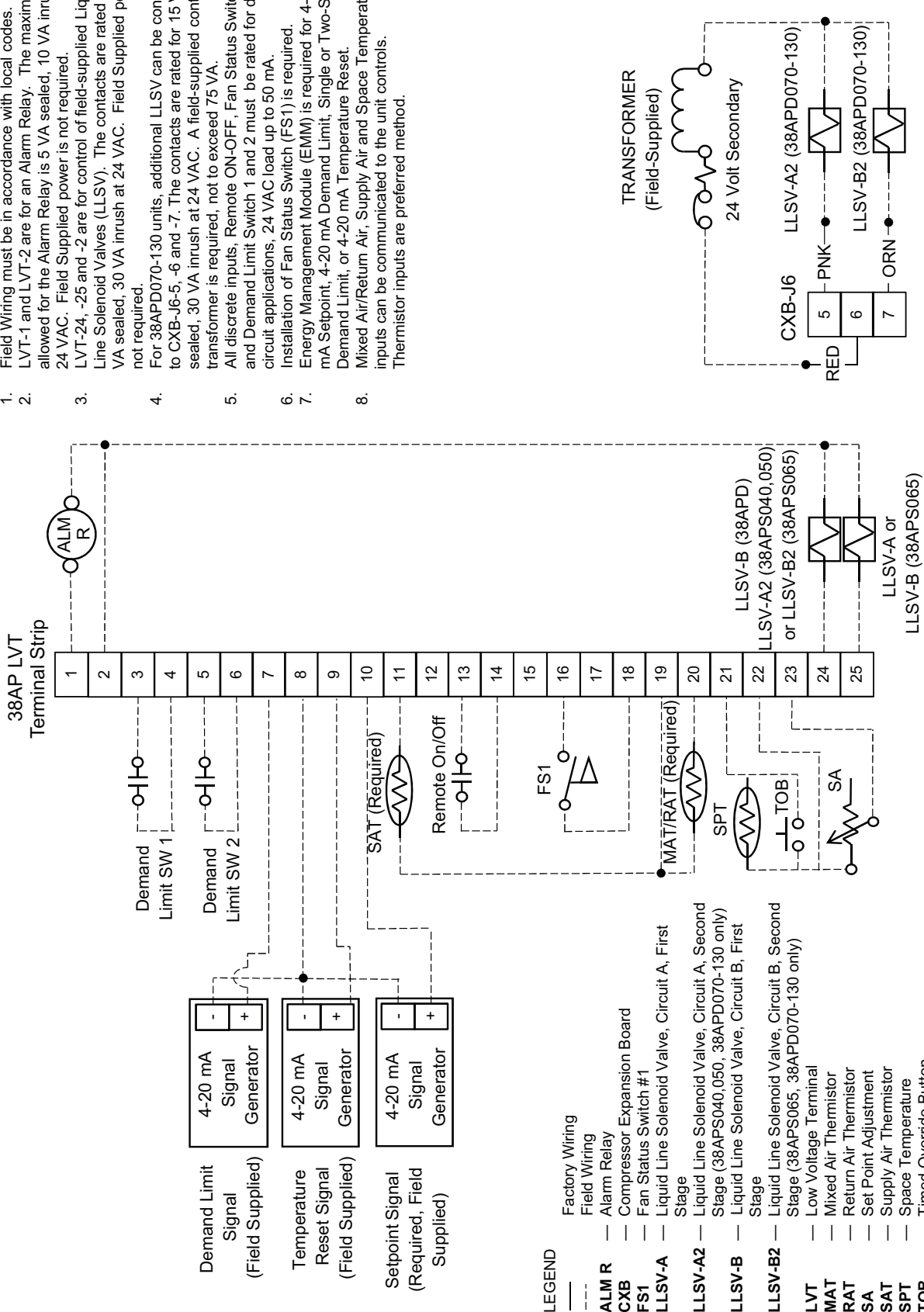



## MAT/RAT AND SAT SENSOR LAYOUT

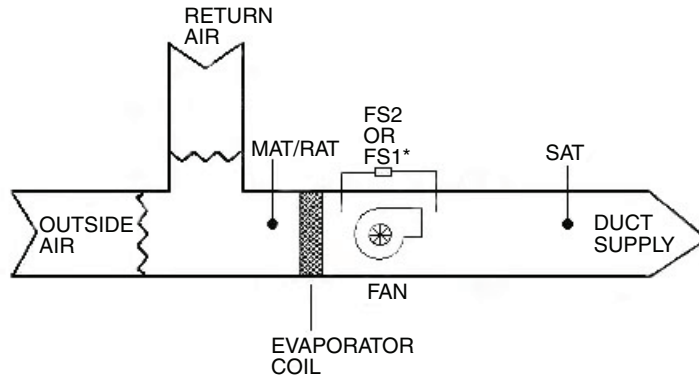

### LEGEND

- FS1** — Fan Status Switch (24-v)
- MAT** — Mixed Air Temperature Sensor
- RAT** — Return Air Temperature Sensor
- SAT** — Supply Air Temperature Sensor

\*FS1 can be pressure differential switch (shown), motor current detection, or sail switch.

## COMMUNICATIONS WIRING

### LVT CCN

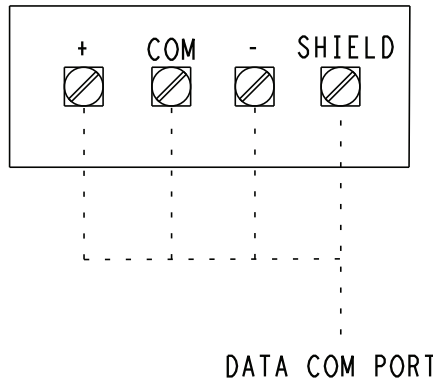

## Installation

The 38APD unit must be installed outdoors.

The 38AP condensing units are not designed for refrigeration duty. If applying with a third-party air-handling unit, a crossplot is required to determine the saturation temperature.

When considering location of the unit, be sure to consult National Electrical Code (NEC, U.S.A.) and local code requirements. Allow sufficient space for airflow, wiring, piping, and service. The placement area must be level and strong enough to support the operating weight of the unit. When unit is in proper location, use of mounting holes in base rails is recommended for securing unit to supporting structure. For mounting unit on vibration isolators, 4 x 24 in. (102 x 610 mm) perimeter support ASTM "C" channels between unit and the isolators are recommended with a minimum of 4 channels per unit. Fasteners for mounting unit are field supplied.

For 38AP025-060: When parallel condensing units are aligned such that coils face each other, a minimum of 6 ft (1829 mm) is recommended. When the parallel arrangement has only one coil drawing air from the space between condensing units, a minimum of 3.5 ft (1067 mm) is recommended. When parallel condensing units have no coils facing each other (a back-to-back arrangement), be sure to maintain the larger of the recommended service clearances associated with each chiller (see the certified drawings). Due to NEC (National Electric Code, U.S.A.) regulations, a minimum clearance of 4 ft (1219 mm) must be maintained on the side of the chiller that has an electrical box. Condensing unit fan discharge must be at least as high as adjacent solid walls.

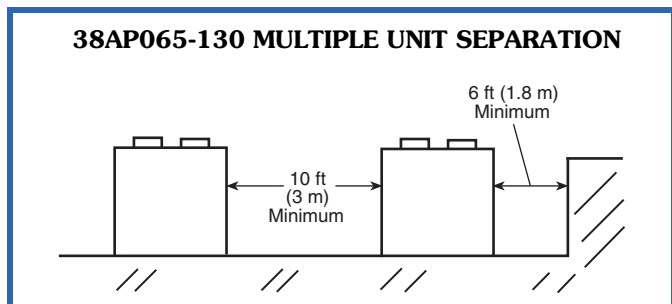
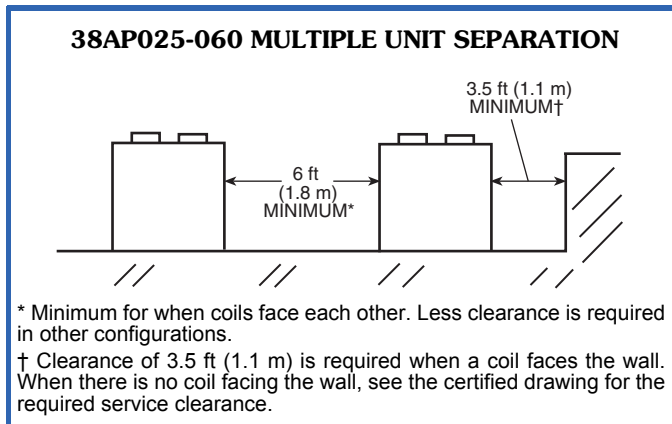

For 38AP065-130: When condensing units are arranged in parallel, a minimum of 10 ft (3048 mm) between condensing units is recommended. Acceptable clearance on the side with a control box can be reduced to 4 ft (1.3 m) due to NEC (National Electric Code, U.S.A.) regulations, without sacrificing performance as long as the remaining three sides are unrestricted. For acceptable clearance with layout involving more than 2 condensing units, contact application engineering.

Refer to certified drawings for airflow clearances. Recommended minimum clearances are 6 ft (1829 mm) for unrestricted airflow and service on sides of unit, 4 ft (1219 mm) on ends, and unrestricted clear air space above the unit. Provide ample space to connect liquid and suction lines to indoor unit. For multiple units, allow 10 ft (3048 mm) separation between airflow surfaces. If walls surround the unit, wall height should not exceed the top of the unit fan discharge. Installation in a pit is not recommended.

The 38AP condensing units are not intended for remote cooler applications. For such purposes, please select a 30 Series chiller with remote cooler.

**IMPORTANT:** Be sure to mount unit level to ensure proper oil return to compressors.

**IMPORTANT:** Do NOT bury refrigerant piping underground. Failure to comply could result in equipment damage.

## Operating limits

Maximum outdoor ambient:

50/60 Hz, full capacity 122°F (50°C)

50/60 Hz, unloaded 125°F (51.6°C)

50/60 Hz, 100% outdoor air application; return air temperature maximum 95°F (35°C)

Minimum operating outdoor air temperature with installed high-efficiency variable condenser fans and wind baffles -20°F (-28.8°C)

Minimum return air temperature 55°F (-12.8°C)

Maximum return air temperature 95°F (35°C)

Range of acceptable saturation suction temperature 35 to 55°F (1.7 to 12.8°C)

Maximum discharge temperature 268°F (131°C)

Minimum suction superheat 12° F (6.7°C)

Maximum vertical liquid lift separation 75 ft (22.8 m)  
 50/60 Hz

Check valves required for all units with linear line length more than 100 ft (30.5 m).

Check valves required for any 38AP025-030 dual circuit units where evaporator is located higher than the condensing unit and the linear line length is more than 55 ft (16.8 m).

Maximum linear separation between condensing unit and air handling unit 200 ft (61 m).

**NOTES:**

1. Select indoor equipment at no less than 300 cfm per ton (40 L/s per kW) (nominal condensing unit capacity).
2. The total combined draw of the 2 field-supplied liquid line solenoid valves and one air handler fan contactor must not exceed 90 va. If the specified va must be exceeded, use a remote relay to control the load.
3. Select equipment to match or to be slightly less than peak load. This provides better humidity control, less unit cycling, and less part load operation.
4. Due to compressor reliability considerations, oil management is critical on split systems. Evaluate oil return when selecting vapor line sizes, especially for partial load conditions.
5. The indoor fan must operate when the outdoor unit is operating.
6. For VAV systems, the total building load is NOT the sum of the individual peak loads. Equipment selected for the sum of the individual peak loads will be oversized.
7. For VAV systems with supply-to-return air recycling, use the equipment room as a return-air plenum.
8. To minimize air recirculation, do not use concentric supply and return grilles.
9. All 38AP condensing units will come with one accumulator per circuit to protect compressors from liquid migration.
10. Ductwork should be sized according to unit size, not building load.
11. A field-supplied 5 to 15% bleed port TXV (thermostatic expansion valve) is required for every application. EXVs are not acceptable.
12. The 38AP condensing units are not suitable for hot gas reheat applications.

## 38AP UNIT AMBIENT LIMITATIONS

### SINGLE CIRCUIT

38APS UNIT SIZE	MINIMUM LOW AMBIENT*† (Standard Unit)	MINIMUM LOW AMBIENT WITH HIGH-EFFICIENCY VARIABLE CONDENSER FANS**	MAXIMUM AMBIENT††
025-065	45°F (7.2°C)	-20°F (-28.9°C)	122°F (50°C)

### DUAL CIRCUITS

38APD UNIT SIZE	MINIMUM LOW AMBIENT*† (Standard Unit)	MINIMUM LOW AMBIENT WITH HIGH-EFFICIENCY VARIABLE CONDENSER FANS**	MAXIMUM AMBIENT††
025-040	32°F (0°C)	-20°F (-28.9°C)	122°F (50°C)
050-060	25°F (-3.9°C)	-20°F (-28.9°C)	122°F (50°C)
070-130	32°F (0°C)	N/A	122°F (50°C)

- \* Temperatures calculated with the minimum number of fans operating per circuit.
- † Minimum outdoor-air operating temperature is based on 90°F (32°C) saturated condensing temperature and 100% capacity.
- \*\* Wind baffles must be included.
- †† Operation above listed temperature depends on the saturated suction temperature at which the unit is operating. Refer to E-Cat for exact limitations.

## 38AP LOADING SEQUENCES

### LOADING SEQUENCES — SINGLE CIRCUIT

38APS UNIT SIZE	LOADING SEQUENCES			
	Standard Unit		Digital Option	
	Range (%)	Number of Steps	Range (%)	Number of Steps
025-030	50, 100	2	17-100	22
040-050	33, 66, 100	3	16-100	27
065	33, 66, 100	3	—	—

### LOADING SEQUENCES — DUAL CIRCUIT

38APD UNIT SIZE	LOADING SEQUENCES			
	Standard Unit		Digital Option	
	Range (%)	Number of Steps	Range (%)	Number of Steps
025-030	50, 100	2	17-100	22
040	27, 50, 73, 100	4	13-100	36
050-060	23, 50, 73, 100	4	11-100	36
070	24, 48, 65, 83, 100	5	11-100	45
080	20, 40, 60, 80, 100	5	9-100	45
090	15, 33, 49, 67, 82, 100	6	7-100	54
100	17, 33, 50, 67, 83, 100	6	8-100	54
115	14, 29, 44, 62, 81, 100	6	7-100	54
130	13, 25, 38, 59, 79, 100	6	6-100	54

## REFRIGERANT PIPING REQUIREMENTS 38APS025-065 SINGLE-CIRCUIT UNITS (60 Hz)

60 Hz	38APS UNIT SIZE	CONN S,L (in.)	TOTAL LINEAR LENGTH OF INTERCONNECTING PIPE, ft (m)															
			0-25 (0-7.6)		26-50 (7.9-15.2)		51-75 (15.5-22.9)		76-100 (23.1-30.5)		101-125 (30.8-38.1)		126-150 (38.4-45.7)		151-175 (46.0-53.3)		176-200 (53.6-61.0)	
			EQUIVALENT LENGTH, ft (m)*															
			0-37 (0-11.3)		38-75 (11.6-22.8)		76-112 (23.2-34.1)		113-150 (34.4-45.7)		151-187 (46.0-57.0)		188-225 (57.3-68.6)		226-262 (68.9-79.9)		263-300 (80.1-91.5)	
			L	S	L	S	L	S	L	S	L	S	L	S	L	S	L	S
025	1-5/8, 5/8	5/8	1-3/8	5/8	1-5/8	7/8	1-5/8	7/8	1-5/8	7/8	2-1/8	7/8	2-1/8	7/8	2-1/8	7/8	2-1/8	
027	1-5/8, 5/8	5/8	1-3/8	7/8	1-5/8	7/8	1-5/8	7/8	2-1/8	7/8	2-1/8	7/8	2-1/8	7/8	2-1/8	7/8	2-1/8	
030	1-5/8, 7/8	7/8	1-3/8	7/8	1-5/8	7/8	2-1/8	7/8	2-1/8	7/8	2-1/8	7/8	2-1/8	7/8	2-1/8	1-1/8	2-1/8	
040	2-1/8, 7/8	7/8	1-5/8	7/8	2-1/8	7/8	2-1/8	7/8	2-1/8	7/8	2-1/8	1-1/8	2-1/8	1-1/8	2-5/8	1-1/8	2-5/8	
050	2-1/8, 7/8	7/8	1-5/8	7/8	2-1/8	7/8	2-1/8	1-1/8	2-1/8	1-1/8	2-5/8	1-1/8	2-5/8	1-1/8	2-5/8	1-1/8	2-5/8	
065	2-5/8, 7/8	7/8	1-5/8	1-1/8	2-1/8	1-1/8	2-1/8	1-1/8	2-1/8	1-1/8	2-5/8	1-1/8	2-5/8	1-1/8	2-5/8	1-3/8	2-5/8	

## 38APD025-130 DUAL-CIRCUIT UNITS (60 Hz)

60 Hz	38APD UNIT SIZE	CONN S,L (in.)	TOTAL LINEAR LENGTH OF INTERCONNECTING PIPE, ft (m)															
			0-25 (0-7.6)		26-50 (7.9-15.2)		51-75 (15.5-22.9)		76-100 (23.1-30.5)		101-125 (30.8-38.1)		126-150 (38.4-45.7)		151-175 (46.0-53.3)		176-200 (53.6-61.0)	
			EQUIVALENT LENGTH, ft (m)*															
			0-37 (0-11.3)		38-75 (11.6-22.8)		76-112 (23.2-34.1)		113-150 (34.4-45.7)		151-187 (46.0-57.0)		188-225 (57.3-68.6)		226-262 (68.9-79.9)		263-300 (80.1-91.5)	
			L	S	L	S	L	S	L	S	L	S	L	S	L	S	L	S
025	Ckt A	1-3/8, 5/8	5/8	1-1/8	5/8	1-1/8	5/8	1-3/8	5/8	1-3/8	5/8	1-3/8	5/8	1-3/8	5/8	1-3/8	5/8	1-5/8
	Ckt B	1-3/8, 5/8	5/8	1-1/8	5/8	1-1/8	5/8	1-3/8	5/8	1-3/8	5/8	1-3/8	5/8	1-3/8	5/8	1-3/8	5/8	1-5/8
027	Ckt A	1-3/8, 5/8	5/8	1-1/8	5/8	1-1/8	5/8	1-3/8	5/8	1-3/8	5/8	1-3/8	5/8	1-3/8	5/8	1-5/8	5/8	1-5/8
	Ckt B	1-3/8, 5/8	5/8	1-1/8	5/8	1-1/8	5/8	1-3/8	5/8	1-3/8	5/8	1-3/8	5/8	1-3/8	5/8	1-5/8	5/8	1-5/8
030	Ckt A	1-3/8, 5/8	5/8	1-1/8	5/8	1-3/8	5/8	1-3/8	5/8	1-3/8	5/8	1-5/8	5/8	1-5/8	7/8	1-5/8	7/8	1-5/8
	Ckt B	1-3/8, 5/8	5/8	1-1/8	5/8	1-3/8	5/8	1-3/8	5/8	1-3/8	5/8	1-5/8	5/8	1-5/8	7/8	1-5/8	7/8	1-5/8
040	Ckt A	1-5/8, 5/8	5/8	1-1/8	5/8	1-3/8	5/8	1-5/8	7/8	1-5/8	7/8	1-5/8	7/8	2-1/8	7/8	2-1/8	7/8	2-1/8
	Ckt B	1-5/8, 5/8	5/8	1-1/8	5/8	1-3/8	5/8	1-5/8	5/8	1-5/8	7/8	1-5/8	7/8	1-5/8	7/8	1-5/8	7/8	2-1/8
050	Ckt A	1-5/8, 5/8	5/8	1-3/8	5/8	1-5/8	7/8	1-5/8	7/8	1-5/8	7/8	2-1/8	7/8	2-1/8	7/8	2-1/8	7/8	2-1/8
	Ckt B	1-5/8, 5/8	5/8	1-3/8	7/8	1-5/8	7/8	1-5/8	7/8	2-1/8	7/8	2-1/8	7/8	2-1/8	7/8	2-1/8	7/8	2-1/8
060	Ckt A	1-5/8, 5/8	5/8	1-3/8	7/8	1-5/8	7/8	1-5/8	7/8	2-1/8	7/8	2-1/8	7/8	2-1/8	7/8	2-1/8	7/8	2-1/8
	Ckt B	1-5/8, 5/8	7/8	1-3/8	7/8	1-5/8	7/8	2-1/8	7/8	2-1/8	7/8	2-1/8	7/8	2-1/8	7/8	2-1/8	1-1/8	2-1/8
070	Ckt A	1-5/8, 7/8	7/8	1-3/8	7/8	1-5/8	7/8	2-1/8	7/8	2-1/8	7/8	2-1/8	7/8	2-1/8	7/8	2-1/8	1-1/8	2-1/8
	Ckt B	2-1/8, 7/8	7/8	1-5/8	7/8	1-5/8	7/8	2-1/8	7/8	2-1/8	7/8	2-1/8	7/8	2-1/8	1-1/8	2-1/8	1-1/8	2-5/8
080	Ckt A	1-5/8, 7/8	7/8	1-3/8	7/8	1-5/8	7/8	2-1/8	7/8	2-1/8	7/8	2-1/8	7/8	2-1/8	7/8	2-1/8	1-1/8	2-1/8
	Ckt B	2-1/8, 7/8	7/8	1-5/8	7/8	2-1/8	7/8	2-1/8	1-1/8	2-1/8	1-1/8	2-5/8	1-1/8	2-5/8	1-1/8	2-5/8	1-1/8	2-5/8
090	Ckt A	2-1/8, 7/8	7/8	1-5/8	7/8	2-1/8	7/8	2-1/8	7/8	2-1/8	7/8	2-1/8	1-1/8	2-1/8	1-1/8	2-5/8	1-1/8	2-5/8
	Ckt B	2-1/8, 7/8	7/8	1-5/8	7/8	2-1/8	7/8	2-1/8	1-1/8	2-1/8	1-1/8	2-5/8	1-1/8	2-5/8	1-1/8	2-5/8	1-1/8	2-5/8
100	Ckt A	2-1/8, 7/8	7/8	1-5/8	7/8	2-1/8	7/8	2-1/8	1-1/8	2-1/8	1-1/8	2-5/8	1-1/8	2-5/8	1-1/8	2-5/8	1-1/8	2-5/8
	Ckt B	2-1/8, 7/8	7/8	1-5/8	7/8	2-1/8	7/8	2-1/8	1-1/8	2-1/8	1-1/8	2-5/8	1-1/8	2-5/8	1-1/8	2-5/8	1-1/8	2-5/8
115	Ckt A	2-1/8, 7/8	7/8	1-5/8	7/8	2-1/8	7/8	2-1/8	1-1/8	2-1/8	1-1/8	2-5/8	1-1/8	2-5/8	1-1/8	2-5/8	1-1/8	2-5/8
	Ckt B	2-5/8, 7/8	7/8	1-5/8	1-1/8	2-1/8	1-1/8	2-1/8	1-1/8	2-1/8	1-1/8	2-5/8	1-1/8	2-5/8	1-1/8	2-5/8	1-3/8	2-5/8
130	Ckt A	2-1/8, 7/8	7/8	1-5/8	7/8	2-1/8	7/8	2-1/8	1-1/8	2-1/8	1-1/8	2-5/8	1-1/8	2-5/8	1-1/8	2-5/8	1-1/8	2-5/8
	Ckt B	2-5/8, 1-1/8	7/8	2-1/8	1-1/8	2-1/8	1-1/8	2-5/8	1-1/8	2-5/8	1-1/8	2-5/8	1-3/8	2-5/8	1-3/8	3-1/8	1-3/8	3-1/8

Legend and notes on page 50.

## REFRIGERANT PIPING REQUIREMENTS (cont) 38APS025-065 SINGLE-CIRCUIT UNITS (50 Hz)

50 Hz	38APS UNIT SIZE	CONN S,L (in.)	TOTAL LINEAR LENGTH OF INTERCONNECTING PIPE, ft (m)															
			0-25 (0-7.6)		26-50 (7.9-15.2)		51-75 (15.5-22.9)		76-100 (23.1-30.5)		101-125 (30.8-38.1)		126-150 (38.4-45.7)		151-175 (46.0-53.3)		176-200 (53.6-61.0)	
			EQUIVALENT LENGTH, ft (m)*															
			0-37 (0-11.3)		38-75 (11.6-22.8)		76-112 (23.2-34.1)		113-150 (34.4-45.7)		151-187 (46.0-57.0)		188-225 (57.3-68.6)		226-262 (68.9-79.9)		263-300 (80.1-91.5)	
			L	S	L	S	L	S	L	S	L	S	L	S	L	S	L	S
025	1-5/8, 5/8	5/8	1-1/8	5/8	1-3/8	5/8	1-5/8	5/8	1-5/8	7/8	1-5/8	7/8	2-1/8	7/8	2-1/8	7/8	2-1/8	
027	1-5/8, 5/8	5/8	1-3/8	5/8	1-3/8	5/8	1-5/8	7/8	1-5/8	7/8	1-5/8	7/8	2-1/8	7/8	2-1/8	7/8	2-1/8	
030	1-5/8, 7/8	5/8	1-3/8	5/8	1-5/8	7/8	1-5/8	7/8	1-5/8	7/8	2-1/8	7/8	2-1/8	7/8	2-1/8	7/8	2-1/8	
040	2-1/8, 7/8	7/8	1-3/8	7/8	1-5/8	7/8	2-1/8	7/8	2-1/8	7/8	2-1/8	7/8	2-1/8	7/8	2-1/8	7/8	2-1/8	
050	2-1/8, 7/8	7/8	1-5/8	7/8	1-5/8	7/8	2-1/8	7/8	2-1/8	7/8	2-1/8	1-1/8	2-1/8	1-1/8	2-5/8	1-1/8	2-5/8	
065	2-5/8, 7/8	7/8	1-5/8	7/8	2-1/8	7/8	2-1/8	1-1/8	2-1/8	1-1/8	2-1/8	1-1/8	2-5/8	1-1/8	2-5/8	1-1/8	2-5/8	

## 38APD025-130 DUAL-CIRCUIT UNITS (50 Hz)

50 Hz	38APD UNIT SIZE	CONN S,L (in.)	TOTAL LINEAR LENGTH OF INTERCONNECTING PIPE, ft (m)															
			0-25 (0-7.6)		26-50 (7.9-15.2)		51-75 (15.5-22.9)		76-100 (23.1-30.5)		101-125 (30.8-38.1)		126-150 (38.4-45.7)		151-175 (46.0-53.3)		176-200 (53.6-61.0)	
			EQUIVALENT LENGTH, ft (m)*															
			0-37 (0-11.3)		38-75 (11.6-22.8)		76-112 (23.2-34.1)		113-150 (34.4-45.7)		151-187 (46.0-57.0)		188-225 (57.3-68.6)		226-262 (68.9-79.9)		263-300 (80.1-91.5)	
			L	S	L	S	L	S	L	S	L	S	L	S	L	S	L	S
025	Ckt A	1-3/8, 5/8	5/8	1-1/8	5/8	1-1/8	5/8	1-1/8	5/8	1-3/8	5/8	1-3/8	5/8	1-3/8	5/8	1-3/8	5/8	1-3/8
	Ckt B	1-3/8, 5/8	5/8	1-1/8	5/8	1-1/8	5/8	1-1/8	5/8	1-3/8	5/8	1-3/8	5/8	1-3/8	5/8	1-3/8	5/8	1-3/8
027	Ckt A	1-3/8, 5/8	5/8	1-1/8	5/8	1-1/8	5/8	1-1/8	5/8	1-3/8	5/8	1-3/8	5/8	1-3/8	5/8	1-3/8	5/8	1-3/8
	Ckt B	1-3/8, 5/8	5/8	1-1/8	5/8	1-1/8	5/8	1-1/8	5/8	1-3/8	5/8	1-3/8	5/8	1-3/8	5/8	1-3/8	5/8	1-3/8
030	Ckt A	1-3/8, 5/8	5/8	1-1/8	5/8	1-1/8	5/8	1-3/8	5/8	1-3/8	5/8	1-3/8	5/8	1-3/8	5/8	1-5/8	5/8	1-5/8
	Ckt B	1-3/8, 5/8	5/8	1-1/8	5/8	1-1/8	5/8	1-3/8	5/8	1-3/8	5/8	1-3/8	5/8	1-3/8	5/8	1-5/8	5/8	1-5/8
040	Ckt A	1-5/8, 5/8	5/8	1-1/8	5/8	1-3/8	5/8	1-3/8	5/8	1-5/8	5/8	1-5/8	5/8	1-5/8	7/8	1-5/8	7/8	2-1/8
	Ckt B	1-5/8, 5/8	5/8	1-1/8	5/8	1-3/8	5/8	1-3/8	5/8	1-3/8	5/8	1-5/8	5/8	1-5/8	7/8	1-5/8	7/8	1-5/8
050	Ckt A	1-5/8, 5/8	5/8	1-1/8	5/8	1-3/8	5/8	1-5/8	5/8	1-5/8	7/8	1-5/8	7/8	2-1/8	7/8	2-1/8	7/8	2-1/8
	Ckt B	1-5/8, 5/8	5/8	1-3/8	5/8	1-3/8	5/8	1-5/8	7/8	1-5/8	7/8	1-5/8	7/8	2-1/8	7/8	2-1/8	7/8	2-1/8
060	Ckt A	1-5/8, 5/8	5/8	1-3/8	5/8	1-3/8	5/8	1-5/8	7/8	1-5/8	7/8	1-5/8	7/8	2-1/8	7/8	2-1/8	7/8	2-1/8
	Ckt B	1-5/8, 5/8	5/8	1-3/8	5/8	1-5/8	7/8	1-5/8	7/8	1-5/8	7/8	2-1/8	7/8	2-1/8	7/8	2-1/8	7/8	2-1/8
070	Ckt A	1-5/8, 7/8	5/8	1-3/8	5/8	1-5/8	7/8	1-5/8	7/8	1-5/8	7/8	2-1/8	7/8	2-1/8	7/8	2-1/8	7/8	2-1/8
	Ckt B	2-1/8, 7/8	5/8	1-3/8	7/8	1-5/8	7/8	2-1/8	7/8	2-1/8	7/8	2-1/8	7/8	2-1/8	7/8	2-1/8	7/8	2-1/8
080	Ckt A	1-5/8, 7/8	5/8	1-3/8	5/8	1-5/8	7/8	1-5/8	7/8	1-5/8	7/8	2-1/8	7/8	2-1/8	7/8	2-1/8	7/8	2-1/8
	Ckt B	2-1/8, 7/8	7/8	1-5/8	7/8	1-5/8	7/8	2-1/8	7/8	2-1/8	7/8	2-1/8	1-1/8	2-1/8	1-1/8	2-5/8	1-1/8	2-5/8
090	Ckt A	2-1/8, 7/8	7/8	1-3/8	7/8	1-5/8	7/8	2-1/8	7/8	2-1/8	7/8	2-1/8	7/8	2-1/8	7/8	2-1/8	7/8	2-1/8
	Ckt B	2-1/8, 7/8	7/8	1-5/8	7/8	1-5/8	7/8	2-1/8	7/8	2-1/8	7/8	2-1/8	1-1/8	2-1/8	1-1/8	2-5/8	1-1/8	2-5/8
100	Ckt A	2-1/8, 7/8	7/8	1-5/8	7/8	1-5/8	7/8	2-1/8	7/8	2-1/8	7/8	2-1/8	1-1/8	2-1/8	1-1/8	2-5/8	1-1/8	2-5/8
	Ckt B	2-1/8, 7/8	7/8	1-5/8	7/8	1-5/8	7/8	2-1/8	7/8	2-1/8	7/8	2-1/8	1-1/8	2-1/8	1-1/8	2-5/8	1-1/8	2-5/8
115	Ckt A	2-1/8, 7/8	7/8	1-5/8	7/8	1-5/8	7/8	2-1/8	7/8	2-1/8	7/8	2-1/8	1-1/8	2-1/8	1-1/8	2-5/8	1-1/8	2-5/8
	Ckt B	2-5/8, 7/8	7/8	1-5/8	7/8	2-1/8	7/8	2-1/8	1-1/8	2-1/8	1-1/8	2-1/8	1-1/8	2-5/8	1-1/8	2-5/8	1-1/8	2-5/8
130	Ckt A	2-1/8, 7/8	7/8	1-5/8	7/8	1-5/8	7/8	2-1/8	7/8	2-1/8	7/8	2-1/8	1-1/8	2-1/8	1-1/8	2-5/8	1-1/8	2-5/8
	Ckt B	2-5/8, 1-1/8	1-1/8	2-1/8	1-1/8	2-1/8	1-1/8	2-5/8	1-1/8	2-5/8	1-1/8	2-5/8	1-1/8	2-5/8	1-1/8	3-1/8	1-3/8	3-1/8

Legend and notes on page 50.

## REFRIGERANT PIPING REQUIREMENTS (cont)

### 38APS025-065 SINGLE-CIRCUIT UNITS DOUBLE SUCTION RISER (60 Hz)

60 Hz	38APS UNIT SIZE	CONN S,L (in.)	TOTAL LINEAR LENGTH OF INTERCONNECTING PIPE, ft (m)																							
			0-25 (0-7.6)			26-50 (7.9-15.2)			51-75 (15.5-22.9)			76-100 (23.1-30.5)			101-125 (30.8-38.1)			126-150 (38.4-45.7)			151-175 (46.0-53.3)			176-200 (53.6-61.0)		
			EQUIVALENT LENGTH, ft (m)*																							
			0-37 (0-11.3)			38-75 (11.6-22.8)			76-112 (22.2-34.1)			113-150 (34.4-45.7)			151-187 (46.0-57.0)			188-225 (57.3-68.6)			226-262 (68.9-79.9)			263-300 (80.1-91.5)		
A	B	C	A	B	C	A	B	C	A	B	C	A	B	C	A	B	C	A	B	C	A	B	C			
025	1-5/8, 5/8	—	—	—	—	—	—	—	—	—	—	—	—	1-3/8	1-5/8	2-1/8	1-3/8	1-5/8	2-1/8	1-3/8	1-5/8	2-1/8	1-3/8	1-5/8	2-1/8	
027	1-5/8, 5/8	—	—	—	—	—	—	—	—	—	1-3/8	1-5/8	2-1/8	1-3/8	1-5/8	2-1/8	1-3/8	1-5/8	2-1/8	1-3/8	1-5/8	2-1/8	1-3/8	1-5/8	2-1/8	
030	1-5/8, 7/8	—	—	—	—	—	—	1-3/8	1-5/8	2-1/8	1-3/8	1-5/8	2-1/8	1-3/8	1-5/8	2-1/8	1-3/8	1-5/8	2-1/8	1-3/8	1-5/8	2-1/8	1-3/8	1-5/8	2-1/8	
040	2-1/8, 7/8	—	—	—	1-3/8	1-5/8	2-1/8	1-3/8	1-5/8	2-1/8	1-3/8	1-5/8	2-1/8	1-3/8	1-5/8	2-1/8	1-3/8	1-5/8	2-1/8	1-5/8	2-1/8	2-5/8	1-5/8	2-1/8	2-5/8	
050	2-1/8, 7/8	—	—	—	1-3/8	1-5/8	2-1/8	1-3/8	1-5/8	2-1/8	1-3/8	1-5/8	2-1/8	1-5/8	2-1/8	2-5/8	1-5/8	2-1/8	2-5/8	1-5/8	2-1/8	2-5/8	1-5/8	2-1/8	2-5/8	
065	2-5/8, 7/8	—	—	—	—	—	—	—	—	—	—	—	—	1-5/8	2-1/8	2-5/8	1-5/8	2-1/8	2-5/8	1-5/8	2-1/8	2-5/8	1-5/8	2-1/8	2-5/8	

### 38APD025-130 DUAL-CIRCUIT UNITS DOUBLE SUCTION RISER (60 Hz)

60 Hz	38APD UNIT SIZE	CONN S,L (in.)	TOTAL LINEAR LENGTH OF INTERCONNECTING PIPE, ft (m)																							
			0-25 (0-7.6)			26-50 (7.9-15.2)			51-75 (15.5-22.9)			76-100 (23.1-30.5)			101-125 (30.8-38.1)			126-150 (38.4-45.7)			151-175 (46.0-53.3)			176-200 (53.6-61.0)		
			EQUIVALENT LENGTH, ft (m)*																							
			0-37 (0-11.3)			38-75 (11.6-22.8)			76-112 (22.2-34.1)			113-150 (34.4-45.7)			151-187 (46.0-57.0)			188-225 (57.3-68.6)			226-262 (68.9-79.9)			263-300 (80.1-91.5)		
A	B	C	A	B	C	A	B	C	A	B	C	A	B	C	A	B	C	A	B	C	A	B	C			
025	Ckt A	1-3/8, 5/8	—	—	—	—	—	—	—	—	—	—	—	—	—	—	—	—	—	—	—	—	—			
	Ckt B	1-3/8, 5/8	—	—	—	—	—	—	—	—	—	—	—	—	—	—	—	—	—	—	—	—	—			
027	Ckt A	1-3/8, 5/8	—	—	—	—	—	—	—	—	—	—	—	—	—	—	—	—	—	—	—	—	—			
	Ckt B	1-3/8, 5/8	—	—	—	—	—	—	—	—	—	—	—	—	—	—	—	—	—	—	—	—	—			
030	Ckt A	1-3/8, 5/8	—	—	—	—	—	—	—	—	—	—	—	—	—	—	—	—	—	—	—	—	—			
	Ckt B	1-3/8, 5/8	—	—	—	—	—	—	—	—	—	—	—	—	—	—	—	—	—	—	—	—	—			
040	Ckt A	1-5/8, 5/8	—	—	—	—	—	—	—	—	—	—	—	—	—	—	—	1-3/8	1-5/8	2-1/8	1-3/8	1-5/8	2-1/8			
	Ckt B	1-5/8, 5/8	—	—	—	—	—	—	—	—	—	—	—	—	—	—	—	—	—	—	1-3/8	1-5/8	2-1/8			
050	Ckt A	1-5/8, 5/8	—	—	—	—	—	—	—	—	—	—	—	—	1-3/8	1-5/8	2-1/8	1-3/8	1-5/8	2-1/8	1-3/8	1-5/8	2-1/8			
	Ckt B	1-5/8, 5/8	—	—	—	—	—	—	1-3/8	1-5/8	2-1/8	1-3/8	1-5/8	2-1/8	1-3/8	1-5/8	2-1/8	1-3/8	1-5/8	2-1/8	1-3/8	1-5/8	2-1/8			
060	Ckt A	1-5/8, 5/8	—	—	—	—	—	—	1-3/8	1-5/8	2-1/8	1-3/8	1-5/8	2-1/8	1-3/8	1-5/8	2-1/8	1-3/8	1-5/8	2-1/8	1-3/8	1-5/8	2-1/8			
	Ckt B	1-5/8, 5/8	—	—	—	—	—	—	1-3/8	1-5/8	2-1/8	1-3/8	1-5/8	2-1/8	1-3/8	1-5/8	2-1/8	1-3/8	1-5/8	2-1/8	1-3/8	1-5/8	2-1/8			
070	Ckt A	1-5/8, 7/8	—	—	—	—	—	—	1-3/8	1-5/8	2-1/8	1-3/8	1-5/8	2-1/8	1-3/8	1-5/8	2-1/8	1-3/8	1-5/8	2-1/8	1-3/8	1-5/8	2-1/8			
	Ckt B	2-1/8, 7/8	—	—	—	—	—	—	1-3/8	1-5/8	2-1/8	1-3/8	1-5/8	2-1/8	1-3/8	1-5/8	2-1/8	1-3/8	1-5/8	2-1/8	1-5/8	2-1/8	2-5/8			
080	Ckt A	1-5/8, 7/8	—	—	—	—	—	—	1-3/8	1-5/8	2-1/8	1-3/8	1-5/8	2-1/8	1-3/8	1-5/8	2-1/8	1-3/8	1-5/8	2-1/8	1-3/8	1-5/8	2-1/8			
	Ckt B	2-1/8, 7/8	—	—	—	1-3/8	1-5/8	2-1/8	1-3/8	1-5/8	2-1/8	1-3/8	1-5/8	2-1/8	1-5/8	2-1/8	2-5/8	1-5/8	2-1/8	2-5/8	1-5/8	2-1/8	2-5/8			
090	Ckt A	2-1/8, 7/8	—	—	—	1-3/8	1-5/8	2-1/8	1-3/8	1-5/8	2-1/8	1-3/8	1-5/8	2-1/8	1-3/8	1-5/8	2-1/8	1-5/8	2-1/8	2-5/8	1-5/8	2-1/8	2-5/8			
	Ckt B	2-1/8, 7/8	—	—	—	1-3/8	1-5/8	2-1/8	1-3/8	1-5/8	2-1/8	1-3/8	1-5/8	2-1/8	1-5/8	2-1/8	2-5/8	1-5/8	2-1/8	2-5/8	1-5/8	2-1/8	2-5/8			
100	Ckt A	2-1/8, 7/8	—	—	—	1-3/8	1-5/8	2-1/8	1-3/8	1-5/8	2-1/8	1-3/8	1-5/8	2-1/8	1-5/8	2-1/8	2-5/8	1-5/8	2-1/8	2-5/8	1-5/8	2-1/8	2-5/8			
	Ckt B	2-1/8, 7/8	—	—	—	1-3/8	1-5/8	2-1/8	1-3/8	1-5/8	2-1/8	1-3/8	1-5/8	2-1/8	1-5/8	2-1/8	2-5/8	1-5/8	2-1/8	2-5/8	1-5/8	2-1/8	2-5/8			
115	Ckt A	2-1/8, 7/8	—	—	—	—	—	—	—	—	—	—	—	—	1-5/8	2-1/8	2-5/8	1-5/8	2-1/8	2-5/8	1-5/8	2-1/8	2-5/8			
	Ckt B	2-5/8, 7/8	—	—	—	—	—	—	—	—	—	—	—	—	1-5/8	2-1/8	2-5/8	1-5/8	2-1/8	2-5/8	1-5/8	2-1/8	2-5/8			
130	Ckt A	2-1/8, 7/8	—	—	—	1-3/8	1-5/8	2-1/8	1-3/8	1-5/8	2-1/8	1-3/8	1-5/8	2-1/8	1-5/8	2-1/8	2-5/8	1-5/8	2-1/8	2-5/8	1-5/8	2-1/8	2-5/8			
	Ckt B	2-5/8, 1-1/8	—	—	—	—	—	—	1-5/8	2-1/8	2-5/8	1-5/8	2-1/8	2-5/8	1-5/8	2-1/8	2-5/8	1-5/8	2-1/8	2-5/8	3-1/8	1-5/8	3-1/8			

Legend and notes on page 50.



## REFRIGERANT PIPING REQUIREMENTS (cont)

### 38APS025-065 SINGLE-CIRCUIT UNITS DOUBLE SUCTION RISER (50 Hz)

50 Hz	38APS UNIT SIZE	CONN S,L (in.)	TOTAL LINEAR LENGTH OF INTERCONNECTING PIPE, ft (m)																							
			0-25 (0-7.6)			26-50 (7.9-15.2)			51-75 (15.5-22.9)			76-100 (23.1-30.5)			101-125 (30.8-38.1)			126-150 (38.4-45.7)			151-175 (46.0-53.3)			176-200 (53.6-61.0)		
			EQUIVALENT LENGTH, ft (m)*																							
			0-37 (0-11.3)			38-75 (11.6-22.8)			76-112 (22.2-34.1)			113-150 (34.4-45.7)			151-187 (46.0-57.0)			188-225 (57.3-68.6)			226-262 (68.9-79.9)			263-300 (80.1-91.5)		
A	B	C	A	B	C	A	B	C	A	B	C	A	B	C	A	B	C	A	B	C	A	B	C			
025	1-5/8, 5/8	—	—	—	—	—	—	—	—	—	—	—	—	—	—	—	1-3/8	1-5/8	2-1/8	1-3/8	1-5/8	2-1/8	1-3/8	1-5/8	2-1/8	
027	1-5/8, 5/8	—	—	—	—	—	—	—	—	—	—	—	—	—	—	—	1-3/8	1-5/8	2-1/8	1-3/8	1-5/8	2-1/8	1-3/8	1-5/8	2-1/8	
030	1-5/8, 7/8	—	—	—	—	—	—	—	—	—	—	—	—	1-3/8	1-5/8	2-1/8	1-3/8	1-5/8	2-1/8	1-3/8	1-5/8	2-1/8	1-3/8	1-5/8	2-1/8	
040	2-1/8, 7/8	—	—	—	—	—	—	1-3/8	1-5/8	2-1/8	1-3/8	1-5/8	2-1/8	1-3/8	1-5/8	2-1/8	1-3/8	1-5/8	2-1/8	1-3/8	1-5/8	2-1/8	1-3/8	1-5/8	2-1/8	
050	2-1/8, 7/8	—	—	—	—	—	—	1-3/8	1-5/8	2-1/8	1-3/8	1-5/8	2-1/8	1-3/8	1-5/8	2-1/8	1-3/8	1-5/8	2-1/8	1-5/8	2-1/8	2-5/8	1-5/8	2-1/8	2-5/8	
065	2-5/8, 7/8	—	—	—	1-3/8	1-5/8	2-1/8	1-3/8	1-5/8	2-1/8	1-3/8	1-5/8	2-1/8	1-3/8	1-5/8	2-1/8	1-5/8	2-1/8	2-5/8	1-5/8	2-1/8	2-5/8	1-5/8	2-1/8	2-5/8	

Legend and notes on page 50.

## REFRIGERANT PIPING REQUIREMENTS (cont)

### 38APD025-130 DUAL-CIRCUIT UNITS DOUBLE SUCTION RISER (50 Hz)

50 Hz	38APD UNIT SIZE	CONN S,L (in.)	TOTAL LINEAR LENGTH OF INTERCONNECTING PIPE, ft (m)																							
			0-25 (0-7.6)			26-50 (7.9-15.2)			51-75 (15.5-22.9)			76-100 (23.1-30.5)			101-125 (30.8-38.1)			126-150 (38.4-45.7)			151-175 (46.0-53.3)			176-200 (53.6-61.0)		
			EQUIVALENT LENGTH, ft (m)*																							
			0-37 (0-11.3)			38-75 (11.6-22.8)			76-112 (22.2-34.1)			113-150 (34.4-45.7)			151-187 (46.0-57.0)			188-225 (57.3-68.6)			226-262 (68.9-79.9)			263-300 (80.1-91.5)		
A	B	C	A	B	C	A	B	C	A	B	C	A	B	C	A	B	C	A	B	C	A	B	C			
025	Ckt A	1-3/8, 5/8	—	—	—	—	—	—	—	—	—	—	—	—	—	—	—	—	—	—	—	—	—			
	Ckt B	1-3/8, 5/8	—	—	—	—	—	—	—	—	—	—	—	—	—	—	—	—	—	—	—	—	—			
027	Ckt A	1-3/8, 5/8	—	—	—	—	—	—	—	—	—	—	—	—	—	—	—	—	—	—	—	—	—			
	Ckt B	1-3/8, 5/8	—	—	—	—	—	—	—	—	—	—	—	—	—	—	—	—	—	—	—	—	—			
030	Ckt A	1-3/8, 5/8	—	—	—	—	—	—	—	—	—	—	—	—	—	—	—	—	—	—	—	—	—			
	Ckt B	1-3/8, 5/8	—	—	—	—	—	—	—	—	—	—	—	—	—	—	—	—	—	—	—	—	—			
040	Ckt A	1-5/8, 5/8	—	—	—	—	—	—	—	—	—	—	—	—	—	—	—	—	—	—	1-3/8	1-5/8	2-1/8			
	Ckt B	1-5/8, 5/8	—	—	—	—	—	—	—	—	—	7/8	1-3/8	1-5/8	7/8	1-3/8	1-5/8	7/8	1-3/8	1-5/8	7/8	1-3/8	1-5/8			
050	Ckt A	1-5/8, 5/8	—	—	—	—	—	—	—	—	—	—	—	—	1-3/8	1-5/8	2-1/8	1-3/8	1-5/8	2-1/8	1-3/8	1-5/8	2-1/8			
	Ckt B	1-5/8, 5/8	—	—	—	—	—	—	—	—	—	—	—	—	1-3/8	1-5/8	2-1/8	1-3/8	1-5/8	2-1/8	1-3/8	1-5/8	2-1/8			
060	Ckt A	1-5/8, 5/8	—	—	—	—	—	—	—	—	—	—	—	—	1-3/8	1-5/8	2-1/8	1-3/8	1-5/8	2-1/8	1-3/8	1-5/8	2-1/8			
	Ckt B	1-5/8, 5/8	—	—	—	—	—	—	—	—	—	1-3/8	1-5/8	2-1/8	1-3/8	1-5/8	2-1/8	1-3/8	1-5/8	2-1/8	1-3/8	1-5/8	2-1/8			
070	Ckt A	1-5/8, 7/8	—	—	—	—	—	—	—	—	—	1-3/8	1-5/8	2-1/8	1-3/8	1-5/8	2-1/8	1-3/8	1-5/8	2-1/8	1-3/8	1-5/8	2-1/8			
	Ckt B	2-1/8, 7/8	—	—	—	1-3/8	1-5/8	2-1/8	1-3/8	1-5/8	2-1/8	1-3/8	1-5/8	2-1/8	1-3/8	1-5/8	2-1/8	1-3/8	1-5/8	2-1/8	1-3/8	1-5/8	2-1/8			
080	Ckt A	1-5/8, 7/8	—	—	—	—	—	—	—	—	—	1-3/8	1-5/8	2-1/8	1-3/8	1-5/8	2-1/8	1-3/8	1-5/8	2-1/8	1-3/8	1-5/8	2-1/8			
	Ckt B	2-1/8, 7/8	—	—	—	1-3/8	1-5/8	2-1/8	1-3/8	1-5/8	2-1/8	1-3/8	1-5/8	2-1/8	1-3/8	1-5/8	2-1/8	1-5/8	2-1/8	2-5/8	1-5/8	2-1/8	2-5/8			
090	Ckt A	2-1/8, 7/8	—	—	—	1-3/8	1-5/8	2-1/8	1-3/8	1-5/8	2-1/8	1-3/8	1-5/8	2-1/8	1-3/8	1-5/8	2-1/8	1-3/8	1-5/8	2-1/8	1-3/8	1-5/8	2-1/8			
	Ckt B	2-1/8, 7/8	—	—	—	1-3/8	1-5/8	2-1/8	1-3/8	1-5/8	2-1/8	1-3/8	1-5/8	2-1/8	1-3/8	1-5/8	2-1/8	1-5/8	2-1/8	2-5/8	1-5/8	2-1/8	2-5/8			
100	Ckt A	2-1/8, 7/8	—	—	—	1-3/8	1-5/8	2-1/8	1-3/8	1-5/8	2-1/8	1-3/8	1-5/8	2-1/8	1-3/8	1-5/8	2-1/8	1-5/8	2-1/8	2-5/8	1-5/8	2-1/8	2-5/8			
	Ckt B	2-1/8, 7/8	—	—	—	1-3/8	1-5/8	2-1/8	1-3/8	1-5/8	2-1/8	1-3/8	1-5/8	2-1/8	1-3/8	1-5/8	2-1/8	1-5/8	2-1/8	2-5/8	1-5/8	2-1/8	2-5/8			
115	Ckt A	2-1/8, 7/8	—	—	—	1-3/8	1-5/8	2-1/8	1-3/8	1-5/8	2-1/8	1-3/8	1-5/8	2-1/8	1-3/8	1-5/8	2-1/8	1-5/8	2-1/8	2-5/8	1-5/8	2-1/8	2-5/8			
	Ckt B	2-5/8, 7/8	—	—	1-3/8	1-5/8	2-1/8	1-3/8	1-5/8	2-1/8	1-3/8	1-5/8	2-1/8	1-5/8	2-1/8	2-5/8	1-5/8	2-1/8	2-5/8	1-5/8	2-1/8	2-5/8				
130	Ckt A	2-1/8, 7/8	—	—	—	1-3/8	1-5/8	2-1/8	1-3/8	1-5/8	2-1/8	1-3/8	1-5/8	2-1/8	1-3/8	1-5/8	2-1/8	1-3/8	1-5/8	2-5/8	1-3/8	1-5/8	2-5/8			
	Ckt B	2-5/8, 1-1/8	—	—	—	1-5/8	2-1/8	2-5/8	1-5/8	2-1/8	2-5/8	1-5/8	2-1/8	2-5/8	1-5/8	2-1/8	2-5/8	1-5/8	2-5/8	3-1/8	1-5/8	2-5/8	3-1/8			

**LEGEND**

L — Liquid Line  
S — Suction Line

\* Equivalent Length shown is based on the Total Linear Length plus an additional 50% for fittings and valves. If application requires more than 50% additional losses for fittings and valves, calculate the equivalent length and find pipe size using the Equivalent Length columns.

**NOTES:**

- Shading indicates double suction riser or reduced riser is required on circuit where suction gas flow is up.
- Maximum vertical separation between evaporator and condensing unit is 75 ft (22.8 m).
- Suction and liquid line sizing is based on pressure drop equivalent to 2°F (1.1°C) at nominal rating conditions.

4. All pipe sizes are OD inches. Equivalent sizes in millimeters follow:

in.	mm
1/2	12.7
5/8	15.9
7/8	22.2
1-1/8	28.6
1-3/8	34.9
1-5/8	41.3
2-1/8	54.0
2-5/8	66.7
3-1/8	79.4

## SUCTION LINE PIPING

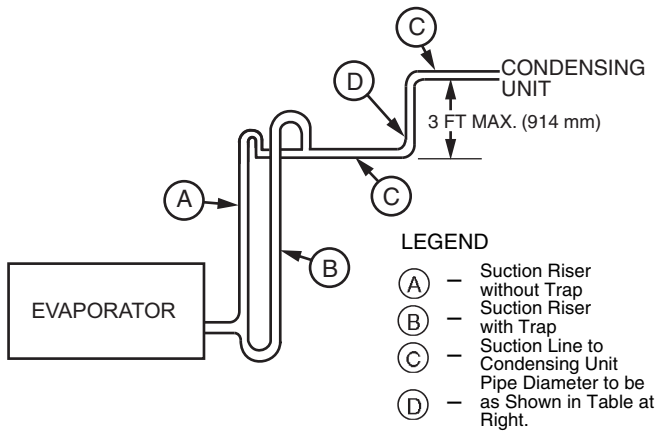

38AP UNIT SIZE	D PIPE DIAMETER					
	DUAL CIRCUIT				SINGLE CIRCUIT	
	CIRCUIT A		CIRCUIT B		in.	mm
	in.	mm	in.	mm		
025	1-1/8	29	1-1/8	29	1-3/8	35
027	1-1/8	29	1-1/8	29	1-3/8	35
030	1-1/8	29	1-1/8	29	1-3/8	35
040	1-3/8	35	1-1/8	29	1-5/8	41
050	1-3/8	35	1-3/8	35	1-5/8	41
060	1-3/8	35	1-5/8	41	—	—
065	—	—	—	—	2-1/8	54
070	1-5/8	41	1-5/8	41	—	—
080	1-5/8	41	1-5/8	41	—	—
090	1-5/8	41	1-5/8	41	—	—
100	1-5/8	41	1-5/8	41	—	—
115	1-5/8	41	2-1/8	54	—	—
130	1-5/8	41	2-1/8	54	—	—

## Commercial Air-Cooled Condensing Units

### HVAC Guide Specifications

Size Range:

**25 to 130 Nominal Tons at 60 Hz**

**88 to 457 Nominal kW at 60 Hz**

**21 to 108 Nominal Tons at 50 Hz**

**73 to 381 Nominal kW at 50 Hz**

With Greenspeed® Intelligence:

**25 to 60 Nominal Tons at 60 Hz**

**88 to 211 Nominal kW at 60 Hz**

**21 to 50 Nominal Tons at 50 Hz**

**73 to 176 Nominal kW at 50 Hz**

Carrier Model Number: **38APD, 38APS**

#### Part 1 — General

##### 1.01 SYSTEM DESCRIPTION

Outdoor-mounted, air-cooled condensing unit with Puron® refrigerant (R-410A) suitable for on-the-ground or rooftop installation. The 38APS unit shall have one refrigeration circuit and shall consist of two or three rotary scroll compressors. The 38APD unit shall have two independent refrigeration circuits and shall consist of two, four, five or six rotary scroll compressors. Unit shall have air-cooled coils, propeller-type condenser fans, a control box, and shall discharge condenser air vertically upward as shown on certified drawings. Unit shall be used in refrigeration circuit with a central station air-handling unit or direct-expansion coils.

For units that incorporate Greenspeed intelligence, all fans are controlled with variable speed fan drive motors. Unit software shall be specifically developed to coordinate optimal fan speed for application conditions and provide refrigerant circuit optimization, resulting in higher part load efficiency and reduced acoustic levels.

##### 1.02 QUALITY ASSURANCE

- A. Unit performance shall be rated in accordance with AHRI (Air-Conditioning, Heating, and Refrigeration Institute) Standard 365, latest edition (U.S.A).
- B. Unit construction shall comply with latest edition of ASHRAE (American Society of Heating, Refrigerating, and Air-Conditioning Engineers) 15 Safety Code, UL 1995, and ASME (American Society of Mechanical Engineers) applicable codes (U.S.A. codes).
- C. The management system governing the manufacturer of the product is ISO (International Organization for Standardization) 9001: 2015 certified.
- D. Base unit shall be constructed in accordance with UL (Underwriters Laboratories) standards and CSA (Canadian Standards Association).
- E. Painted parts shall withstand 1000 hours in constant neutral salt spray under ASTM B117 conditions with a 1mm scribe per ASTM D1654. After test, painted parts shall show no signs of wrinkling or cracking, no loss of adhesion, no evidence of blistering, and the mean creepage shall not exceed 1/4 in.

(Rating  $\geq 4$  per ASTM D1654) on either side of the scribe line.

- F. Design pressure shall be 650 psig (4482 kPa).
- G. Unit shall be functional checked at the factory.
- H. Lifting holes shall be provided to facilitate rigging.

##### 1.03 DELIVERY, STORAGE, AND HANDLING

Unit shall be shipped as single package and shall be stored and handled per the unit manufacturer's recommendations.

##### 1.04 WARRANTY (FOR INCLUSION BY SPECIFYING ENGINEER)

#### Part 2 — Products

##### 2.01 EQUIPMENT

###### A. General:

Factory assembled, single-piece, air-cooled condensing unit. Contained within the unit enclosure shall be all factory wiring, piping, controls, compressors, nitrogen holding charge, and special features required prior to field start-up.

###### B. Unit Cabinet:

1. Cabinet shall be galvanized steel casing with a baked enamel powder or pre-painted finish.
2. Control box access panels shall be hinged for service access.

###### C. Fans:

1. Condenser fans shall be direct-drive propeller type, discharging air vertically upward.
2. All condenser fan motors shall be totally enclosed 3-phase type with permanently lubricated ball bearings, class F insulation and internal, automatic-reset thermal overload protection or manual reset calibrated circuit breakers.
3. Fans on units with Greenspeed intelligence shall be controlled by a variable-frequency drive, and the drive shall include a DC link reactor.
4. Shafts shall have inherent corrosion resistance.
5. Fan blades shall be statically and dynamically balanced.
6. Condenser-fan openings shall be equipped with PVC-coated steel wire safety guards.

###### D. Compressors:

1. Compressors shall be rotary scroll.
2. Operating oil charge and a crankcase heater control oil dilution.
3. Compressors shall be mounted on two rails having rubber in shear vibration isolators.
4. Staging of compressors shall provide unloading capability. Digital compressor unloading control shall be available as an option on one circuit (not available on size 065 unit).
5. Compressor motors shall be cooled by refrigerant gas passing through motor windings and shall have either internal line break thermal and current overload protection or external current

overload modules with compressor temperature sensors.

## E. Condenser Coils:

1. Coil shall be air-cooled microchannel heat exchanger (MCHX) and shall have a series of flat tubes containing a series of multiple, parallel flow microchannels layered between the refrigerant manifolds. Microchannel coils shall consist of a two-pass arrangement. Coil construction shall consist of aluminum alloys for the fins, tubes and manifolds in combination with a corrosion-resistant coating on the tubes.
2. Tubes shall be cleaned, dehydrated, and sealed.
3. Assembled condenser coils shall be leak tested and pressure tested at 650 psig (4482 kPa).
4. To plan the unit installation and for ease of maintenance/coil removal on unit sizes 38AP065-130, all refrigerant piping entering and leaving the condenser coils shall be located on only one side of the condensing unit so the coils can be removed (when needed) from the side free of piping. This is important to consider because removing the coils from the header side, although possible, involves extra labor due to extra bending and brazing of the coil headers.

## F. Refrigeration Components:

1. Refrigeration circuit components shall include liquid line temperature relief device, pressure transducers, liquid line shutoff valve, suction shutoff valve, suction line accumulators, nitrogen holding charge, and compressor oil.
2. Long line length check valves are required for liquid line installation on all linear line length applications of more than 100 ft (30.5 m) to prevent liquid migration during unit shutdown. For any 025-030 size dual circuit unit application where evaporator is located higher than the condensing unit, check valves are required for linear line length above 55 ft (16.8 m).
3. Units shall include one factory-installed suction line accumulator for each refrigerant circuit.

## G. Controls and Safeties:

1. Unit *ComfortLink* controls shall include:
  - a. Scrolling marquee display module shall be used for accessing condensing unit information, reading sensor values, and testing the condensing unit. The scrolling marquee display is a 4-key, 4-character, 16-segment LED (light-emitting diode) display. Eleven mode LEDs shall be located on the display as well as an Alarm Status LED. The display shows all of the *ComfortLink* control codes (with 60-character expandable clear language), plus set points, time of day, temperatures, pressures, and superheat. Additional information can be

displayed all at once with the accessory Navigator™ display.

- b. Carrier Comfort Network® (CCN) system capability.
- c. Unit control with standard pressure transducer, discharge pressure transducer and suction temperature thermistors.
- d. Current alarm list and alarm history list on display.
- e. Automatic compressor lead/lag control.
- f. Service run test capability.
- g. Compressor minimum run time (3 minutes) and minimum off time (3 minutes).
- h. Service diagnostic mode.
- i. Self-contained low voltage control circuit.
- j. Cycle condenser fans to maintain proper head pressure control.
- k. Capacity control with staging compressors.
- l. Optional digital scrolls to stage compressors and cycle digital compressor for maintaining desired leaving air temperature set point.
- m. Alarm relay output to indicate when unit is in alarm condition.

## 2. Minimum unit safety devices shall include:

Solid-state compressor lockout to provide optional reset capability at the space thermostat if any of the following safety devices trip and shut off compressor.

- a. Compressor lockout protection for internal or external overload.
- b. Low pressure protection.
- c. High pressure protection (high pressure switch or internal).
- d. Compressor reverse rotation protection.
- e. Loss of charge protection.
- f. Low suction superheat protection.
- g. Short cycle protection.
- h. Suction and discharge pressure transducers.
- i. Circuit breakers or fuses for short circuit protection of compressors.

## H. Operating Characteristics:

1. The capacity of the condensing unit shall meet or exceed \_\_\_ Btuh (\_\_\_ kW) at a suction temperature of \_\_\_°F (\_\_\_°C). The power consumption at full load shall not exceed \_\_\_ Btuh (\_\_\_ kW).
2. The combination of the condensing unit and the evaporator or air-handling unit shall have a total net cooling capacity of \_\_\_ Btuh (\_\_\_ kW) or greater at conditions of \_\_\_ cfm (\_\_\_ L/s) entering-air temperature at the evaporator at \_\_\_°F (\_\_\_°C) wet bulb and \_\_\_°F (\_\_\_°C) dry bulb, and air entering the condensing unit at \_\_\_°F (\_\_\_°C).

3. The system shall have an Energy Efficiency Ratio (EER) of \_\_\_\_ Btuh/watt or greater at standard AHRI conditions.

## I. Electrical Requirements:

All unit power wiring shall enter unit cabinet at a single location (115 and 130 size units available with dual point power with terminal block).

## J. Special Features:

### 1. High-efficiency variable condenser fans:

All fans on the unit shall have variable speed fan motors to provide higher part load efficiency and reduced acoustic levels. Each fan circuit shall have a factory-installed, independent variable speed drive with display. Variable speed drives are rated IP-55 enclosures and UL Listed. The use of this option, with the addition of wind baffles, shall allow running with outdoor ambient temperatures down to  $-20^{\circ}\text{F}$  ( $-28.9^{\circ}\text{C}$ ). This option is available on unit sizes 025-060.

### 2. Optional Condenser Coil Materials:

#### a. E-coated microchannel coils:

E-coated aluminum microchannel coil shall have a flexible epoxy polymer coating uniformly applied to all coil external surface areas without material bridging between fins or louvers. Coating process shall ensure complete coil encapsulation, including all exposed fin edges. E-coat shall have a thickness of 0.8 to 1.2 mil with top coat having a uniform dry film thickness from 1.0 to 2.0 mil on all external coil surface areas including fin edges. E-coated coils shall have superior hardness characteristics of 2H per ASTM D3363-00 and cross hatch adhesion of 4B-5B per ASTM D3359-02. Impact resistance shall be up to 160 in./lb (ASTM D2794-93). E-coated coil shall have superior impact resistance with no cracking, chipping, or peeling per NSF/ANSI 51-2002 Method 10.2. E-coated aluminum microchannel coils shall be capable of withstanding 8,000-hour salt spray test in accordance with the ASTM (American Society for Testing and Materials) B-117 Standard.

#### b. Aluminum fin/copper tube coils:

Coil shall be constructed of seamless copper tubes mechanically bonded to aluminum fins. Fins shall have wavy enhancements. These condenser coils are recommended with remote cooler applications. These coils are not recommended for corrosive environments.

#### c. Pre-coated aluminum-fin coils:

Coil shall have a durable epoxy-phenolic coating to provide protection in mildly corrosive coastal environments. Coating shall be applied to the aluminum fin stock prior to the fin stamping process to create an inert barrier between the aluminum fin and copper tube.

Epoxy-phenolic barrier shall minimize galvanic action between dissimilar metals.

#### d. E-coated aluminum-fin coils:

Coil shall have a flexible epoxy polymer coating uniformly applied to all coil surface areas without material bridging between fins. Coating process shall ensure complete coil encapsulation. Color shall be high gloss black with gloss;  $60^{\circ}$  of 65 to 90% per ASTM ID523-89. Uniform dry film thickness from 0.8 to 1.2 mil on all surface areas including fin edges. Superior hardness characteristics of 2H per ASTM D3363-92A and cross hatch adhesion of 4B-5B per ASTM D3359-93. Impact resistance shall be up to 160 in./lb (ASTM D2794-93). Humidity and water immersion resistance shall be up to minimum 1000 and 250 hours respectively (ASTM D2247-92 and ASTM D870-92). E-coated aluminum-fin coils shall be capable of withstanding an 8000-hour salt spray test in accordance with the ASTM (American Society for Testing and Materials) (U.S.A.) B-117 Standard. Coil construction shall be aluminum fins mechanically bonded to copper tubes.

### 3. Sound Reduction:

- a. Low sound fan for sound reduction is available as a factory-installed option or field-installed accessory for all units.
- b. Low sound compressor blankets for additional sound reduction are available as a factory-installed option on all units having low sound fans or as a field-installed accessory.

### 4. Digital Compressor Option:

Modification shall include digital compressor to provide incremental steps for tighter temperature control. The digital compressor shall be available as a factory-installed option for all units except size 065.

### 5. Non-Fused Disconnect:

A non-fused disconnect is available as a factory-installed option for all units having single point power connection units.

### 6. Long Line Length Check Valves:

Long line length check valves are available as options shipped with the unit or accessories shipped separately. In either case, field installation is required.

### 7. High Short Circuit Current Rating (SCCR):

The optional high SCCR interrupt capability shall allow the unit to tolerate a 65 kA (208/230v, 380v and 460-v units) or 25 kA (575-v units) short circuit current for a brief period of time while protecting downstream components. The high SCCR option shall provide a higher level of protection than the standard unit (option for 60 Hz only). High



- interrupt shall be available as a factory-installed option strictly in conjunction with a non-fused disconnect and only with single-point power connection.
8. Navigator™ Hand Held Display:
    - a. Portable hand held display module with a minimum of 4 lines and 20 characters per line, of clear English, French, Spanish, or Portuguese language.
    - b. Display menus shall provide clear language descriptions of all menu items, operating modes, configuration points and alarm diagnostics. Reference to factory codes shall not be accepted.
    - c. RJ-14 connection plug shall allow display module to be connected to factory-installed receptacle.
    - d. Industrial grade coiled extension cord shall allow the display module to be moved around the unit.
    - e. Magnets shall hold the display module to any sheet metal panel to allow hands-free operation.
    - f. Display module shall have NEMA (National Electrical Manufacturers Association, U.S.A.) 4x housing suitable for use in outdoor environments.
    - g. Display shall have back light and contrast adjustment for easy viewing in bright sunlight or night conditions.
    - h. Navigator module shall have raised surface buttons with positive tactile response.
    - i. Navigator module shall be available as field-installed accessory for all units.
  9. BACnet Communication Option:

The BACnet Communication option shall provide factory-installed communication capability with a BACnet MS/TP network. Allows integration with i-Vu® Open control system or a BACnet building automation system.
  10. BACnet Translator Control:

BACnet control shall be available as a field-installed accessory for all units to provide interface between unit and a BACnet Local Area Network (LAN, i.e., MS/TP EIA-485).
  11. LON Translator Control:

Unit shall be supplied with field-installed interface between the chiller and a Local Operating Network (LON, i.e., LonWorks FT-10A ANSI/EIA-709.1). LON shall be available as a field-installed accessory for all units.
  12. Touch Pilot™ Display:

Touch Pilot remote mount touch screen display for network attachment to unit shall be available as a field-installed accessory for all units.
  13. Energy Management Module (EMM):

The EMM shall provide remote set point, demand limit control, and percent capacity input. The EMM is not needed with use of BACnet or LON accessory kit.
  14. Security Grilles/Hail Guards:

Units shall be supplied with factory-installed or field-installed louvered, sheet metal panels which securely fasten to the unit to provide condenser coil protection against hail and physical damage.
  15. Vibration Isolation Pads:

Neoprene vibration isolation pads (24 in. x 3 in. x 1/4 in.) shall be available for field installation to reduce vibration transmission from the compressor through the floor and into the conditioned space.
  16. Wind Baffle Kit:

Wind baffles facilitate operation down to -20°F (-29°C) when used in conjunction with high-efficiency variable condenser fans. The combination of wind baffles and high-efficiency variable condenser fans is available on unit sizes 025-060.
  17. Seismic Certification:

A seismic unit modification is available which will result in a unit SDS (seismic design acceleration parameter) level of 2.5 for 38AP025-065 units and 2.1 for 38AP070-130 units.

