



RM-49-HC

Glass Door Merchandiser with Swing Door



RM-49-HC
08/04/23
Item # 13544

W x D x H

60" x 29.75" x 78"



Item #: _____
 Project: _____
 Qty: _____
 AIA#: _____

Features

- ▶ **Curved vertical corners with silver aluminum exterior provide enhanced product display**
- ▶ **Forced air evaporator for quick temperature pull down**
- ▶ **Energy saving hot gas loop on front edge of cabinet helps prevent condensation**

- Listed under NSF/ANSI Standard 7 for the storage and/or display of packaged or bottled products.
- Large glass doors are energy efficient Low-E multi pane glass
- (5) white epoxy coated shelves per section with product stops are standard
- Automatic energy saving hot gas loop on front edge of refrigeration compartment helps prevent condensation particularly in hot humid environments
- LED illuminated exterior canopy
- Energy efficient vertical LED interior lights illuminate products on display
- Door is mounted on heavy duty hinges with self-closing mechanism
- Silver painted aluminum exterior with NSF approved white steel interior and stainless steel floor
- Environmentally friendly CFC-Free Polyurethane insulation with cyclopentane blowing agent.
- Stainless steel shelf clips adjustable in 1/2" increments on anodized aluminum supports
- Refrigerant flow is controlled with a capillary tube
- 8 Foot cord and plug
- 2 inch leveling legs standard

Capacity:
 20 oz. bottles: 630
 12 oz. bottles: 1440

Container Qty: 14



Dimensions / Capacity

Two Section RM-49-HC

Interior Storage Capacity (CF)	42.61 ft ³
Overall Width x Depth	60" x 29.75"
Height	78"
Depth with Door Open	58.1"
Adjustable Shelves	5 per section
Shelf Dimensions (W x D)	27" x 21.75"
Crated Shipping Weight	610 lbs.
Crated Width x Depth x Height	63" x 32.25" x 86"

Electrical / Refrigeration

Two Section RM-49-HC

Voltage	115/60/1
HACR Breaker	15.0 Amps
Electrical Connection (NEMA)	5-15P ⓘ
Voltage Range	104-126
Ambient Temp. Range	60° to 86°F
Control Setpoint Range	28° to 40°F
Amperage	7.6
Energy Consumption (kWh/day) @ASHRAE	4.37
Approx. Nominal Compres. BTU/HR (HP)	1670(1/2HP)
Refrigerant / Charge Amount (oz)	R290 / (4.9oz.)

Options

- Organizer shelf (HS-5295) Requires 2 sets of:
- Price tag holder (HS-5296) 4" Casters (HS-5288)
- Epoxy Shelf (HS-5319)

Warranty

3 Year - Parts and Labor on entire machine.
 5 Year - Parts on Compressor
 Valid in United States, Canada, Puerto Rico and U.S. Territories. Contact factory for warranty in other countries.

If GFCI is required, a GFCI breaker MUST be used in lieu of GFCI receptacle

Hoshizaki reserves the right to change specifications without notice.



RM-49-HC

Glass Door Merchandiser with Swing Door

RM-49-HC
08/04/23
Item # 13544

FRONT VIEW

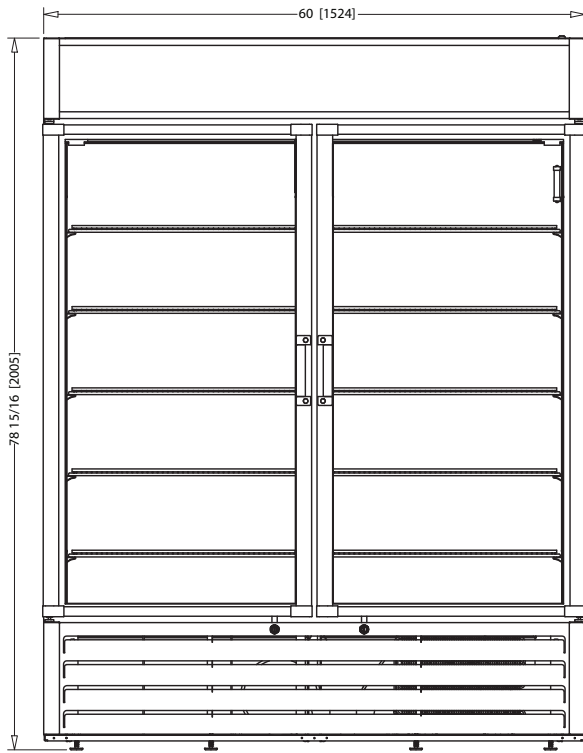

SIDE VIEW

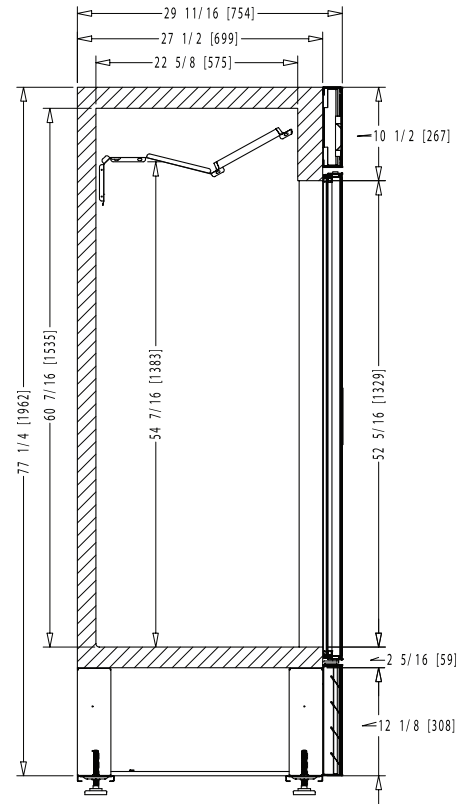

PLAN VIEW

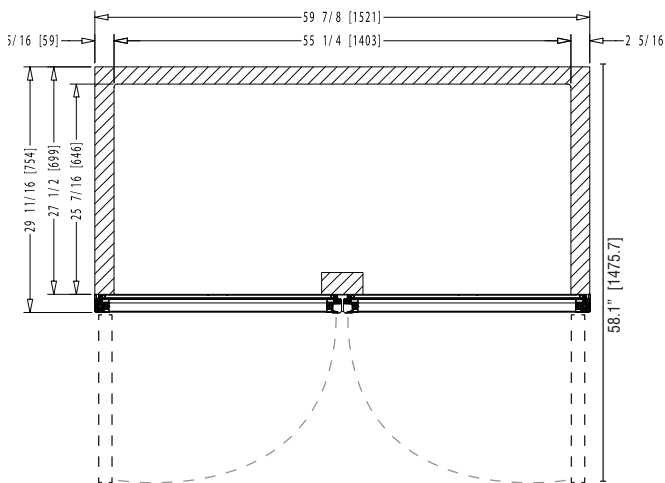

HEADER DIMS

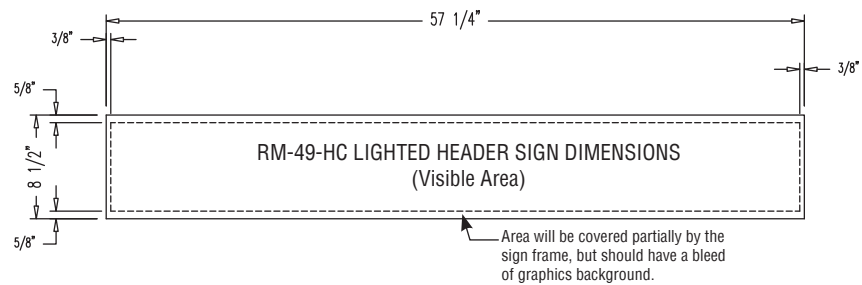

Graphic Requirements:

- 360 dpi resolution. Scale 1=1
- Colors for CMYK process
- Image with 1/4" of excess by side
- Graphics must be saved in photoshop (with layers) (or your sign company file type requirements)
- Include a full color print out

Material Requirements:

- Thickness: 1/16" (1.5mm)
- Good- Acrylic/Pexiglass, Better - high impact acrysteel, acrylite SG
- Best- Super impact Lexan, Lexan SG Polycarbonate

Note: Texts and important parts of the image should be within the visible area. The visible area is illustrated by dotted lines when it applies.